

# Table of Contents

1. PRECAUTIONS FOR USE .....	22
2. DISPOSAL INSTRUCTIONS - OUR ENVIRONMENT POLICY .....	22
3. SAFETY PRECAUTIONS .....	24
4. GETTING TO KNOW YOUR APPLIANCE .....	25
5. BEFORE INSTALLATION.....	25
6. USING THE HOB.....	26
7. CLEANING AND MAINTENANCE .....	28
8. FITTING THE APPLIANCE.....	29
9. GAS CONNECTION .....	34
10. ADAPTING TO DIFFERENT TYPES OF GAS .....	36
11. FINAL OPERATIONS FOR GAS APPLIANCES.....	38



**INSTRUCTIONS FOR THE USER:** *these provide recommendations for use, a description of the controls and the correct procedures for cleaning and maintaining the appliance*



**INSTRUCTIONS FOR THE INSTALLER:** *these are intended for the qualified engineer who is to install, commission and test the appliance*

## 1. PRECAUTIONS FOR USE



THIS MANUAL IS AN INTEGRAL PART OF THE APPLIANCE. TAKE GOOD CARE OF IT AND KEEP IT TO HAND THROUGHOUT THE HOB'S LIFE CYCLE.

WE URGE YOU TO READ THIS MANUAL AND ALL THE INFORMATION IT CONTAINS CAREFULLY BEFORE USING THE APPLIANCE.

INSTALLATION MUST BE CARRIED OUT BY QUALIFIED STAFF IN COMPLIANCE WITH THE RELEVANT REGULATIONS. THIS APPLIANCE IS INTENDED FOR HOUSEHOLD USE AND COMPLIES WITH THE **EEC DIRECTIVES** CURRENTLY IN FORCE. THE APPLIANCE IS BUILT TO PROVIDE THE FOLLOWING FUNCTION: **COOKING AND HEATING FOODS**; ALL OTHER USES ARE TO BE CONSIDERED IMPROPER.

THE MANUFACTURER DECLINES ALL LIABILITY FOR USES OTHER THAN THOSE STATED ABOVE.

NEVER USE THIS APPLIANCE FOR HEATING ROOMS.



NEVER USE PACKAGING RESIDUES UNATTENDED IN THE HOME. SEPARATE THE VARIOUS WASTE PACKAGING MATERIALS BY TYPE AND CONSIGN THEM TO THE NEAREST SEPARATE DISPOSAL CENTRE.



THIS APPLIANCE IS MARKED ACCORDING TO THE EUROPEAN DIRECTIVE 2002/96/EC ON WASTE ELECTRICAL AND ELECTRONIC EQUIPMENT (WEEE). THIS GUIDELINE IS THE FRAME OF A EUROPEAN-WIDE VALIDITY OF RETURN AND RECYCLING ON WASTE ELECTRICAL AND ELECTRONIC EQUIPMENT.



NEVER OBSTRUCT THE OPENINGS AND SLITS PROVIDED FOR VENTILATION AND HEAT DISPERSAL.



THE NAMEPLATE WITH THE TECHNICAL DATA, SERIAL NUMBER AND MARK ARE IN A VISIBLE POSITION UNDERNEATH THE CASING.

THE NAMEPLATE MUST NEVER BE REMOVED.



## Disposal instructions

GB-IE

### **2. DISPOSAL INSTRUCTIONS - OUR ENVIRONMENT POLICY**

Our products are only packaged using non-pollutant, environment-friendly, recyclable materials. We urge you to cooperate by disposing of the packaging properly. Contact your local dealer or the competent local organisations for the addresses of collection, recycling and disposal facilities.

Never leave all or part of the packaging lying around. Packaging parts, and especially plastic bags, may represent a suffocation hazard for children.

Your old appliance must also be disposed of properly.

**Important:** deliver the appliance to your local organisation authorised to collect scrapped appliances. Proper disposal allows the intelligent recovery of valuable materials.

Cut the power supply lead and remove it and the plug.

## 3. SAFETY PRECAUTIONS



SEE INSTALLATION INSTRUCTIONS FOR SAFETY REGULATIONS FOR ELECTRIC OR GAS APPLIANCES AND FOR VENTILATION FUNCTIONS. IN YOUR INTEREST AND TO ENSURE YOUR SAFETY, BY LAW ALL ELECTRIC APPLIANCES MUST ONLY BE INSTALLED AND SERVICED BY QUALIFIED STAFF, IN ACCORDANCE WITH THE RELEVANT REGULATIONS. OUR APPROVED INSTALLATION ENGINEERS GUARANTEE YOU A JOB WELL DONE.

GAS OR ELECTRIC APPLIANCES MUST ALWAYS BE DISCONNECTED BY SUITABLY SKILLED PEOPLE.



THE PLUG TO BE CONNECTED TO THE POWER SUPPLY LEAD AND THE RELATIVE SOCKET MUST BE OF THE SAME TYPE AND COMPLY WITH THE RELEVANT REGULATIONS.

THE POWER SUPPLY SOCKET MUST BE ACCESSIBLE EVEN AFTER THE APPLIANCE HAS BEEN BUILT-IN.

**NEVER DISCONNECT THE PLUG BY PULLING ON THE POWER SUPPLY LEAD.**



THE APPLIANCE MUST BE CONNECTED TO EARTH IN COMPLIANCE WITH ELECTRICAL SYSTEM SAFETY REGULATIONS.



IMMEDIATELY AFTER INSTALLATION, CARRY OUT A QUICK TEST ON THE APPLIANCE FOLLOWING THE INSTRUCTIONS PROVIDED LATER IN THIS MANUAL. IF THE APPLIANCE FAILS TO OPERATE, DISCONNECT IT FROM THE ELECTRICAL MAINS AND CONTACT YOUR NEAREST SERVICE CENTRE.

**NEVER ATTEMPT TO REPAIR THE APPLIANCE.**



THE APPLIANCE BECOMES VERY HOT DURING USE. OVEN GLOVES SHOULD ALWAYS BE WORN.



**THE APPLIANCE IS INTENDED FOR USE BY ADULTS.** KEEP CHILDREN AT A SAFE DISTANCE AND NEVER ALLOW THEM TO PLAY WITH IT.



AFTER EACH USE, ALWAYS CHECK THAT THE CONTROL KNOBS ARE TURNED TO 0 (OFF).



*The manufacturer declines all responsibility for injury or damage caused by failure to comply with the above regulations or deriving from tampering with even just one part of the appliance and the use of non-original spare parts.*



# Instructions for the User

GB-IE

## 4. GETTING TO KNOW YOUR APPLIANCE

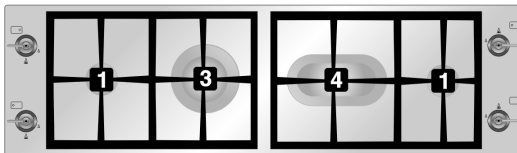
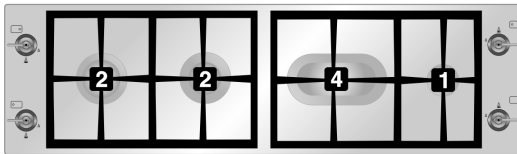
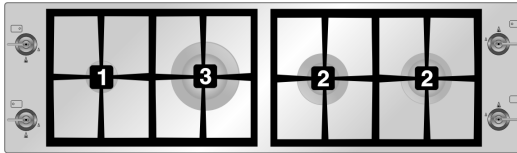

<b>1</b>	Auxiliary Burner (AUX)	<b>3</b>	Rapid Burner (R)
<b>2</b>	Semi-rapid (SR) burner	<b>4</b>	Ultrarapid Burner (UR3) Raised spoke pan stand

## 5. BEFORE INSTALLATION



Never leave packaging residues unattended in the home. Separate waste packaging materials by type and consign them to the nearest separate disposal centre.



The inside of the appliance should be cleaned to remove all manufacturing residues. For further information, see point "7. CLEANING AND MAINTENANCE".



When the electric plates or barbecue (when fitted) are used for the first time, they should be heated to the maximum temperature for long enough to burn off any oily residues left by the manufacturing process, which might contaminate foods with unpleasant smells.



## 6. USING THE HOB

### 6.1 Gas hob



Before lighting the hob burners check that the flame diffuser rings are correctly in place with their respective burner caps, making sure that the holes **A** in the flame diffusers are aligned with the plugs and thermocouples.



The optional grid **B** is for use with woks. To prevent damage to the hob, the appliance comes complete with a raised grid **C**. This grid is intended for use underneath pans which exceed the diameter stated in the table in point "6.3 Pan diameters". All pans more than 30 cm in diameter must only be used on the central burner.

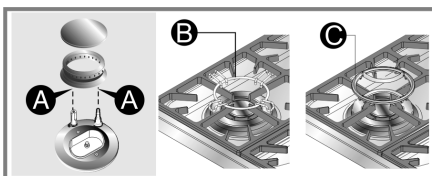

The burner it controls is shown next to each knob. The appliance is equipped with an electronic ignition device. Simply press the knob and turn it anti-clockwise to the maximum flame symbol, until the burner lights. If it does not light within the first 15 seconds, turn the knob to 0 and wait at least 60 seconds before trying to light the burner again.

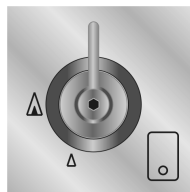

On models equipped with valves, once the burner has ignited, keep the knob pressed down for a few seconds to allow the thermocouple to heat up. The burner may go out when the knob is released: in this case, the thermocouple has not heated up sufficiently. Wait a few moments and repeat the operation, keeping the knob pressed down for longer. This is not necessary on burners not equipped with thermocouple. Once the burner has been ignited, the flame can be regulated as required. After each use of the hob, always check that the control knobs are turned to **O** (off).



If the burners should go out accidentally a safety device will be tripped about 20 seconds later, cutting off the gas supply even if the gas tap is open. In this case, turn the knob back to the off position and wait at least 60 seconds before trying to relight the burner.



# Instructions for the User

GB-IE

## 6.2 Practical hints for using the burners



For better burner efficiency and to minimise gas consumption, use pans with flat, even bottoms with lid and of suitable size for the burner, so that flames do not reach up the sides of the pan (see point "6.3 Pan diameters"). Once the contents come to the boil, turn down the flame far enough to prevent the liquid from boiling over.



When cooking, to prevent burns or damage to the hob all pans or griddle plates must be placed inside the perimeter of the hob.

Take the greatest care when using fats or oils since they may catch fire if overheated.

## 6.3 Pan diameters

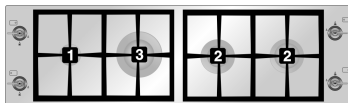

**BURNERS**

**Ø MIN. AND MAX.  
(IN CM)**

- 1 Auxiliary 12 - 16
- 2 Semi rapid 16 - 24
- 3 Rapid 18 - 26
- 4 Fish pan

**SPECIAL OVAL  
PANS**

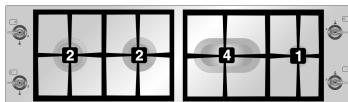

See below for the diameters of the pans which can be used with the raised pan stand:

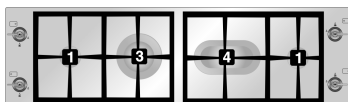

**BURNERS**

**Ø MIN. AND MAX.  
(IN CM)**

- 1 Auxiliary 16 - 24
- 2 Semi rapid 24 - 28
- 3 Rapid 26 - 28

# Instructions for the User



## 7. CLEANING AND MAINTENANCE

**NEVER USE A JET OF STEAM FOR CLEANING THE APPLIANCE.**



**Before carrying out any operations, disconnect the appliance from the electricity supply.**



### 7.1 Cleaning stainless steel



*To keep stainless steel in good condition, it must be cleaned regularly, after each use of the appliance, first allowing it to cool.*

#### 7.1.1 Routine daily cleaning

When cleaning and caring for stainless steel surfaces, always use **only** specific products which do not contain abrasives or chlorine-based acids.

**Instructions for use:** pour the product onto a damp cloth and wipe over the surface, then rinse thoroughly and dry with a soft cloth or chamois leather.

#### 7.1.2 Food stains or spills

Never use metal scouring pads or sharp scrapers which will damage the surface. Use ordinary non-abrasive products for steel, with the aid of wooden or plastic utensils if necessary. Rinse thoroughly and dry with a soft cloth or chamois leather.



### 7.2 Cleaning the gas components

The grids, the burner caps, the flame diffuser rings and the burners can be removed for easier cleaning; wash them in hot water and non-abrasive detergent, taking care to remove all deposits, and wait for them to **dry completely**. Replace the burner caps on their rings, making sure that the holes **A** are perfectly centered with the circular projections **B** on the burners.

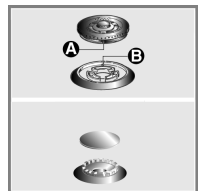

For best performance, the ignition plugs and thermocouples must always be kept thoroughly clean. Check them frequently and if necessary clean them with a wet cloth. Remove any dry residues with a wooden toothpick or a needle.

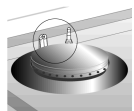





## Instructions for the Installer

GB-IE

### 8. FITTING THE APPLIANCE

#### 8.1 Fitting the appliance in the top



*This appliance is in class 3. The procedures required below must be carried out by a skilled builder and/or joiner.*

*The hob can be installed on various materials, including masonry, metal, solid wood and wood finished with plastic laminates, provided the material is heat-resistant ( $T 90^{\circ} C$ ).*

##### 8.1.1 Installing to a traditional built-in structure

Make a hole in the cabinet top with the dimensions shown here, maintaining a distance of at least **110 mm** from the rear edge. This appliance may be installed against walls higher than the worktop surface, provided the distance "X" shown here is maintained, in order to prevent damage due to overheating. Make sure that there is at least **750 mm** between the hob burners and any shelving placed vertically above them.

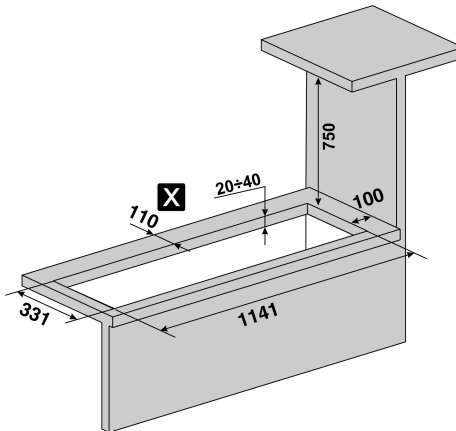

**CAUTION: IF YOU ARE INSTALLING A HOB WITH FISH BURNER, THE DISTANCE "X" FROM THE REAR WALL INCREASES FROM 110 mm TO 300 mm.**

Fit the insulating gasket provided carefully around the outside edge of the hole made in the top, pressing it down with your hands so that its entire surface fits snugly. Now place the 12 brackets supplied to secure the top to the supporting structure. See point "6.2 Securing the appliance to the cabinet"



## 8.1.2 Installation to a flush mounting structure

Make a hole in the top of the cabinet of the size shown in the figure, leaving a space "X" of at least **110 mm** from the rear edge. The underside of the casing must be fully accessible once the appliance has been installed.

This appliance may be installed against walls higher than the worktop surface, provided the distance of 100 mm shown in the figure is maintained, in order to prevent damage due to overheating. Make sure that there is at least **750 mm** between the hob burners and any shelving placed vertically above them (**Fig. 2**).

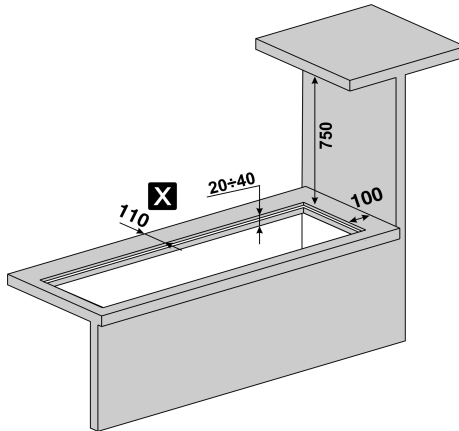

**CAUTION: IF YOU ARE INSTALLING A HOB WITH FISH BURNER, THE DISTANCE "X" FROM THE REAR WALL INCREASES FROM 110 mm TO 300 mm.**



## Instructions for the Installer

GB-IE

This type of appliance also requires a cut 3 mm deep in the top with the dimensions shown in figure 7 (detail **A**). Before fitting the hob, apply the adhesive sponge strip supplied "**B**" along the entire surface of the cut (fig. 7). Now place the 12 brackets supplied to secure the top to the supporting structure. See point "8.2 Securing the appliance to the cabinet".

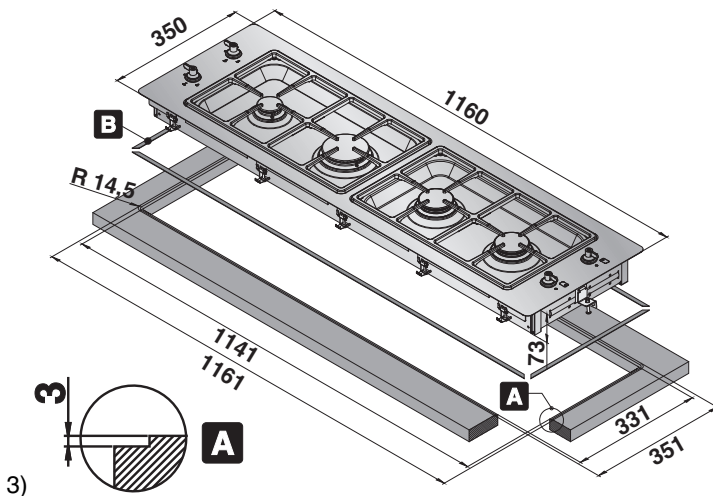



## 8.2 Securing the appliance to the cabinet

### 8.2.1 Securing the side brackets

Fit the two provided brackets to the short sides of the appliance as shown in figura 4-5

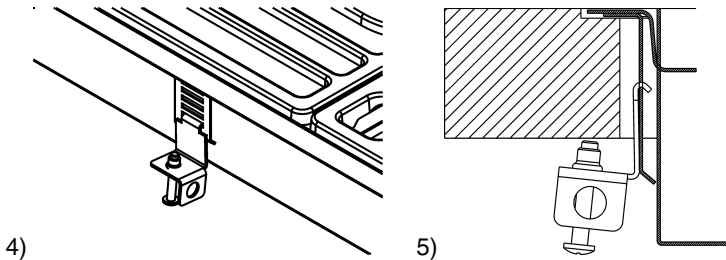

### 8.2.2 Securing the front/rear brackets

The hob is equipped with 10 brackets "A" (see fig. 6) which secure and level it relative to the cabinet top. Depending on whether the hob is to be installed to a cabinet of 20mm to 30mm thickness (Detail "C") or 30mm to 50mm thickness (Detail "B"), the brackets "A" mount to different holes in the hob's casing (see fig. 7).

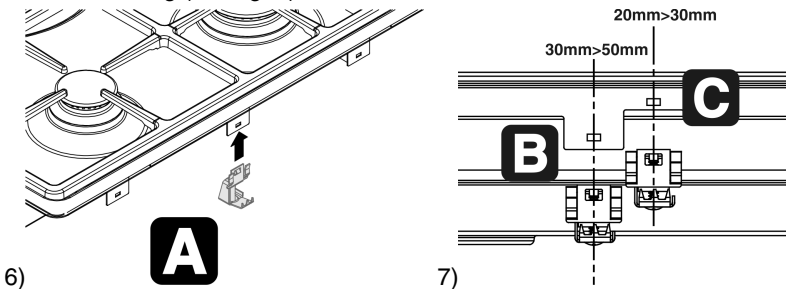

#### **Important:**

- When fixing this product to the supporting structure, do not use mechanical or electric screwdrivers and apply only moderate pressure to the fixing components by hand.
- When fixing the product, always use the brackets provided in all fixing points.
- If this product is installed above an oven, the oven must be fitted with a cooling fan.
- Apply a coat of proofing primer to the cut surface of the top



## Instructions for the Installer

GB-IE

### 8.3 Electrical connection



Check that the power supply voltage and size are as specified on the nameplate below the appliance carter.

**The nameplate must never be removed.**



The appliance must be connected to earth in compliance with electrical system safety regulations.



If a permanent connection is used, the appliance's power supply line must be fitted with an omnipolar breaking device with contact gap of at least **3 mm**, located in an easily accessible position close to the appliance itself.

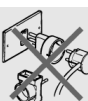

If a socket and plug connection is used, check that they are of the same type. Do not use reducers, adapters or junctions since they may cause overheating or burns.



**Operation at 220-240 V~:** use a type H05V2V2-F three-wire cable (cable of 3 x 1.5 mm<sup>2</sup> for electric hobs and a cable of 3 x 0.75 mm<sup>2</sup> for gas hobs)

The earth wire (yellow-green) must be at least 20 mm longer than the other wires at the end for connection to the appliance.

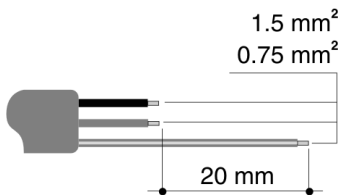

**The manufacturer declines all responsibility** for injury or damage caused by failure to comply with the above regulations or deriving from tampering with even just one part of the appliance.



## 9. GAS CONNECTION

Before installing, check that the local gas main (type and pressure) and the appliance's settings are compatible.

**There are 2 ways to connect the appliance to the domestic gas main:**

- 1- Make two branches with a pipe or steel hose and unite them with a T-fitting just downline of the gas main fitting, or
- 2- Unite the two gas fittings on the appliance itself with a **pipe** and intercept the gas main fitting at the T-fitting.

**In both cases, all pipes connected to the gas main must be equipped with a safety shut off valve.**

The connection to the gas mains may be made using a **copper pipe** or a continuous-wall **steel hose** in accordance with the relevant regulations.

When installation is complete, check for any leaks with a soapy solution, never with a naked light. The appliance has been tested for **G20 (2H) natural gas** at the pressure of 20 mbar.

For use with other types of gas, see point. "10. ADAPTING TO DIFFERENT TYPES OF GAS".

The gas intake connection has an external 1/2" gas thread (ISO 228-1).

**Connection with copper pipe:** The connection to the gas supply mains must be made so that no stresses or strains of any kind are applied to the appliance. The connection can be made using the adapter unit **C** with two conical elements, always fitting the gasket **A** supplied.

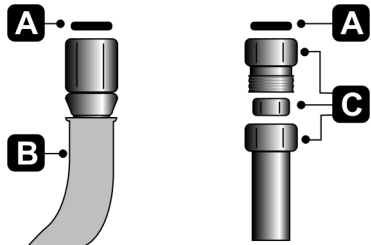

**Connection with steel hose:** Use only continuous wall steel hoses which comply with the relevant regulations, and always fit the provided gasket **A** between the hob fitting and the hose itself **B**.

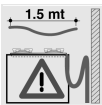

*When connecting with a hose, ensure that the total length of the pipeline is not more than 1.5 metres; also ensure that the hoses do not touch moving parts and are not crushed.*

### 9.1 Bottled gas connection



Use a pressure regulator and make the connection to the gas cylinder in accordance with the relevant regulations. Make sure that the gas supply pressure is as stated in the table in point "10.2 Burner and Nozzle Data Tables".

In this case as well, use a **copper pipe** or a continuous wall **steel hose**.



## Instructions for the Installer

GB-IE

### **9.2 Room ventilation**



The appliance may only be installed in a permanently ventilated room as specified by the relevant regulations. The air flow into the room where the appliance is installed must be sufficient for proper gas combustion and room ventilation. The air intakes, protected by gratings, must be of suitable size (see relevant regulations) and located so that they cannot be even partially obstructed. The kitchen must be kept properly ventilated to disperse the heat and humidity produced by cooking processes: in particular, a window should be opened or the speed of any fans increased after prolonged use.

### **9.3 Combustion gas discharge**



Combustion gases must be discharged by means of hoods connected to a flue with reliable natural draught, or a fan extraction system. An effective extraction system requires careful design by an authorised specialist, and must comply with the regulation distances and positions. After installation, the engineer must issue a certificate of compliance.



## 10. ADAPTING TO DIFFERENT TYPES OF GAS

*Before carrying out the operations described below, disconnect the appliance from the electricity supply.*



The appliance is tested with **G20 (2H) natural gas** at the pressure of 20 mbar. If it is to be used with other types of gas, the burner nozzles have to be changed and the gas taps adjusted to set the minimum flame. To replace the nozzles, proceed as described below.

### 10.1 Changing the hob nozzles

- 1 Remove the pan stands, all the burner caps and the flame diffuser rings
- 2 Use a 7 mm socket wrench to unscrew the burner nozzles;
- 3 Replace the burner nozzles depending on the type of gas to be used (see point "10.2 Burner and Nozzle Data Tables").
- 4 Put the burners back into place correctly.

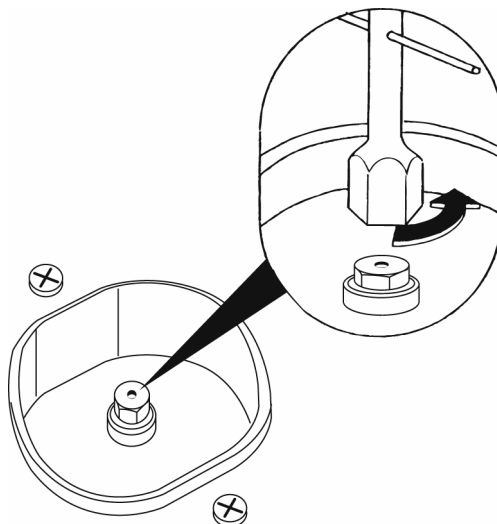





# Instructions for the Installer



## 10.2 Burner and Nozzle Data Tables

Burner	RATED HEAT CAPACITY (kW)	LPG – G30/G31 28/37 mbar					
		Nozzle diameter 1/100 mm	By-pass mm 1/100		Reduced heat capacity (W)	Net g/h G30	Net g/h G31
Auxiliary (!)	1.05	50	30 *	28 **	350	76	75
Semi-rapid (2)	1.75	65	33 *	32 **	450	127	125
Rapid (3)	2.3	75	45 *	42 **	800	167	164
Fish pan (4)	1.9	68	45 *	42 **	900	138	136

\*/\*\*: diameters marked \* and \*\* must be fitted respectively on valves marked \* and \*\*shown in point "11.1 Adjusting the minimum setting for natural gas".

Burner	RATED HEAT CAPACITY (kW)	NATURAL GAS – G20 20 mbar	
		Nozzle diameter 1/100 mm	Reduced heat capacity (W)
Auxiliary (!)	1.05	72	350
Semi-rapid (2)	1.75	97	450
Rapid (3)	2.5	108	800
Fish pan (4)	1.9	94	900



To identify the burners on your hob, refer to the drawings in point "4. GETTING TO KNOW YOUR APPLIANCE".



## 11. FINAL OPERATIONS FOR GAS APPLIANCES

After making the adjustments described above, reassemble the appliance, reversing the procedures described in point "10.1 Changing the hob nozzles".



*After adjusting for use of a gas other than the gas used for testing the appliance, replace the gas setting label inside the warming compartment with the label for the new gas. The label is available from your nearest Authorised Service Centre.*

### 11.1 Adjusting the minimum setting for natural gas

Light the burner and turn it to the minimum setting. Remove the gas tap knob and adjust the regulator screw inside or beside the tap rod (depending on the model) until an even minimum flame is obtained. Put the knob back in place and check the stability of the burner flame (the flame must not go out when the knob is turned quickly from the maximum to the minimum setting). Repeat the operation on all the gas taps.

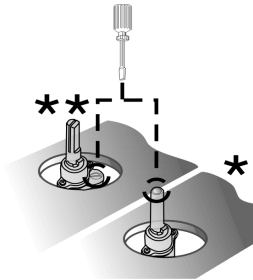

### 11.2 Adjusting the minimum for bottled gas

To adjust the minimum level when using bottled gas, the adjuster screw inside or beside the tap rod must be turned fully clockwise (depending on the models). The diameters of the bypasses for each individual burner are stated in point "10.2 Burner and Nozzle Data Tables".

### 11.3 Greasing the gas taps

Over time, the gas taps may become stiff or jam. Clean their insides and change their lubricating grease. **This operation must be carried out by a skilled technician.**