

**BS 470/471**

**BS 474/475**

**BS 484/485**

Combi-steam oven

---

## Table of contents

---

<b>Important safety information</b>	<b>4</b>
Causes of damage	5
<b>Environmental protection</b>	<b>6</b>
Saving energy	6
Environmentally-friendly disposal	6
<b>Getting to know the appliance</b>	<b>7</b>
Steam oven	7
Display and operating controls	8
Symbols	8
Colours and display	9
Automatic door opening	9
Additional information <b>i</b> and <b>i</b> <sup>®</sup>	9
Cooling fan	9
Function selector positions	10
Accessories	12
Special accessories	12
<b>Before using for the first time</b>	<b>13</b>
Setting the language	13
Setting the time format	13
Setting the clock	13
Setting the date format	13
Setting the date	14
Setting the temperature format	14
Setting the water filter	14
Setting the water hardness	14
Ending initial set-up	15
Calibration	15
Cleaning accessories	15
<b>Water filter</b>	<b>16</b>
Operation with or without a water filter	16
Changing the water filter	16
<b>Activating the appliance</b>	<b>16</b>
Standby	16
Activating the appliance	16
<b>Operating the appliance</b>	<b>17</b>
Cooking compartment	17
Inserting accessories	17
Switching on	18
Misting	18
Steam removal	18
After every use	18
Safety shut-off	18
<b>Timer functions</b>	<b>19</b>
Calling up the timer menu	19
Timer	19
Stopwatch	19
Cooking time	20
End of cooking time	21

<b>Long-term timer</b>	<b>22</b>
Setting the long-term timer	22
<b>Individual recipes</b>	<b>22</b>
Recording a recipe	22
Programming a recipe	23
Entering names	23
Starting recipes	23
Change recipe	24
Deleting recipes	24
<b>Core temperature probe</b>	<b>24</b>
Inserting the core temperature probe in the food to be cooked	25
Setting the core temperature	25
Core temperature guidelines	26
<b>Child lock</b>	<b>27</b>
Activate the child lock	27
Deactivating the child lock	27
<b>Basic settings</b>	<b>28</b>
<b>Cleaning and maintenance</b>	<b>30</b>
Cleaning agents	30
Cleaning programme	31
Drying programme	33
Descaling programme	33
<b>Trouble shooting</b>	<b>35</b>
Power cut	36
Demo mode	36
Replacing the oven light	36
<b>After-sales service</b>	<b>37</b>
<b>Settings table and tips</b>	<b>38</b>
Vegetables	38
Fish	39
Fish – low-temperature steaming	40
Meat – cooking at higher temperatures	41
Meat/poultry – low-temperature cooking	42
Poultry	43
Sous-vide cooking	44
Grilling	47
Side dishes	48
Desserts	48
Miscellaneous	49
Baking	49
Raising dough	51
Regenerating (reheating)	51
Defrosting	52
Preserving	53
Extracting juice (soft fruit)	53
Preparing yoghurt	54
Preparing bulky food	55
Acrylamide in foodstuffs	55

Additional information on products, accessories, replacement parts and services can be found at [www.gaggenau.com](http://www.gaggenau.com) and in the online shop [www.gaggenau-eshop.com](http://www.gaggenau-eshop.com)

## **⚠ Important safety information**

Read these instructions carefully. Only then will you be able to operate your appliance safely and correctly. Retain the instruction manual and installation instructions for future use or for subsequent owners.

This appliance is only intended to be fully fitted in a kitchen. Observe the special installation instructions.

Check the appliance for damage after unpacking it. Do not connect the appliance if it has been damaged in transport.

Only a licensed professional may connect appliances without plugs. Damage caused by incorrect connection is not covered under warranty.

This appliance is intended for domestic use only. The appliance must only be used for the preparation of food and drink. The appliance must be supervised during operation. Only use this appliance indoors.

This appliance is intended for use up to a maximum height of 2000 metres above sea level.

This appliance may be used by children over the age of 8 years old and by persons with reduced physical, sensory or mental capabilities or by persons with a lack of experience or knowledge if they are supervised or are instructed by a person responsible for their safety how to use the appliance safely and have understood the associated hazards.

Children must not play with, on, or around the appliance. Children must not clean the appliance or carry out general maintenance unless they are at least 8 years old and are being supervised.

Keep children below the age of 8 years old at a safe distance from the appliance and power cable.

Always slide accessories into the cooking compartment correctly. See description of accessories in the instruction manual.

### **Risk of fire!**

- Combustible items stored in the cooking compartment may catch fire. Never store combustible items in the cooking compartment. Never open the appliance door if there is smoke inside. Switch off the appliance and unplug it from the mains or switch off the circuit breaker in the fuse box.
- A draught is created when the appliance door is opened. Greaseproof paper may come into contact with the heating element and catch fire. Do not place greaseproof paper loosely over accessories during preheating. Always weight down the greaseproof paper with a dish or a baking tin. Only cover the surface required with greaseproof paper. Greaseproof paper must not protrude over the accessories.

### **Risk of burns!**

- The appliance becomes very hot. Never touch the interior surfaces of the cooking compartment or the heating elements. Always allow the appliance to cool down. Keep children at a safe distance.
- Accessories and ovenware become very hot. Always use oven gloves to remove accessories or ovenware from the cooking compartment.
- Alcoholic vapours may catch fire in the hot cooking compartment. Never prepare food containing large quantities of drinks with a high alcohol content. Only use small quantities of drinks with a high alcohol content. Open the appliance door with care.
- Hot steam may escape during operation. Do not touch the ventilation openings. Keep children away.

## Risk of scalding!

- When you open the appliance door, hot steam can escape. Steam may not be visible, depending on its temperature. When opening, do not stand too close to the appliance. Open the appliance door carefully. Keep children away.
- Hot liquid may spill over the sides of the accessory when it is removed from the cooking compartment. Remove hot accessories with care and always wear oven gloves.

## Risk of electric shock!

- Incorrect repairs are dangerous. Repairs may only be carried out and damaged power cables replaced by one of our trained after-sales technicians. If the appliance is defective, unplug the appliance from the mains or switch off the circuit breaker in the fuse box. Contact the after-sales service.
- The cable insulation on electrical appliances may melt when touching hot parts of the appliance. Never bring electrical appliance cables into contact with hot parts of the appliance.
- Do not use any high-pressure cleaners or steam cleaners, which can result in an electric shock.
- A defective appliance may cause electric shock. Never switch on a defective appliance. Unplug the appliance from the mains or switch off the circuit breaker in the fuse box. Contact the after-sales service.
- The insulation of an incompatible meat probe may be damaged. Only use the meat probe which is recommended for this appliance.

## Causes of damage

### Caution!

- Do not place anything on the cooking compartment floor. Do not cover it with aluminium foil. A build-up of heat could damage the appliance. The cooking compartment floor must always be kept clear. Always place ovenware in a perforated cooking container or on a wire rack.
- Aluminium foil in the cooking compartment must not come into contact with the door panel. This could cause permanent discolouration of the door panel.
- We recommend you install a descaling system for hard mains water. You can inquire with your waterworks to obtain information about your mains water.
- Ovenware must be heat and steam resistant. Silicone baking tins are not suitable for combined operation with steam.
- Use only original accessories in the cooking compartment. Rusting material (such as serving platters or knives and forks) can cause corrosion in the oven interior.
- Use original small parts (e.g. knurled nuts) only. Order small parts from our after-sales service if these should be lost.
- Do not store moist food in the closed cooking compartment for long periods. It can lead to corrosion in the cooking compartment.
- Salt, spicy sauces (e.g. ketchup or mustard) or salted dishes (e.g. cured roast) contain chloride and acids. These corrode the surfaces of stainless steel. Always remove residues immediately.
- Fruit juice may leave stains in the cooking compartment. Always remove fruit juice immediately and wipe the cooking compartment with a moist and dry cloth.
- Improper care of the appliance may lead to corrosion in the cooking compartment. Refer to the care and cleaning instructions in the instruction manual. Clean the cooking compartment each time you use it as soon as the appliance has cooled down. After cleaning the cooking compartment, use the drying programme to dry it.
- Do not detach the door seal. The appliance door will no longer close properly if the door seal is damaged. The fronts of adjacent units could be damaged. Have the door seal replaced.

---

## Environmental protection

---

Your new appliance is particularly energy-efficient. Here you can find tips on how to save even more energy when using the appliance, and how to dispose of your appliance properly.

### Saving energy

- Open the appliance door as little as possible while cooking.
- Use dark, black lacquered or enamelled baking tins for baking. They absorb the heat particularly well.
- It is best to bake several cakes one after the other. The oven will still be hot. This reduces the baking time for the second cake. You can also place two loaf tins next to each other.
- For longer cooking times, you can switch off the steam oven 10 minutes before the end of the cooking time and you can use the residual heat to finish cooking.
- When steaming, you can cook simultaneously on several levels. If dishes require different cooking times, insert the dishes that require the longest time first.

### Environmentally-friendly disposal

Dispose of packaging in an environmentally-friendly manner.



This appliance is labelled in accordance with European Directive 2012/19/EU concerning used electrical and electronic appliances (waste electrical and electronic equipment - WEEE). The guideline determines the framework for the return and recycling of used appliances as applicable throughout the EU.

---

## Getting to know the appliance

---

Use this section to familiarise yourself with your new appliance. The control panel and the individual operating controls are explained. You will find information on the cooking compartment and the accessories.

### Steam oven

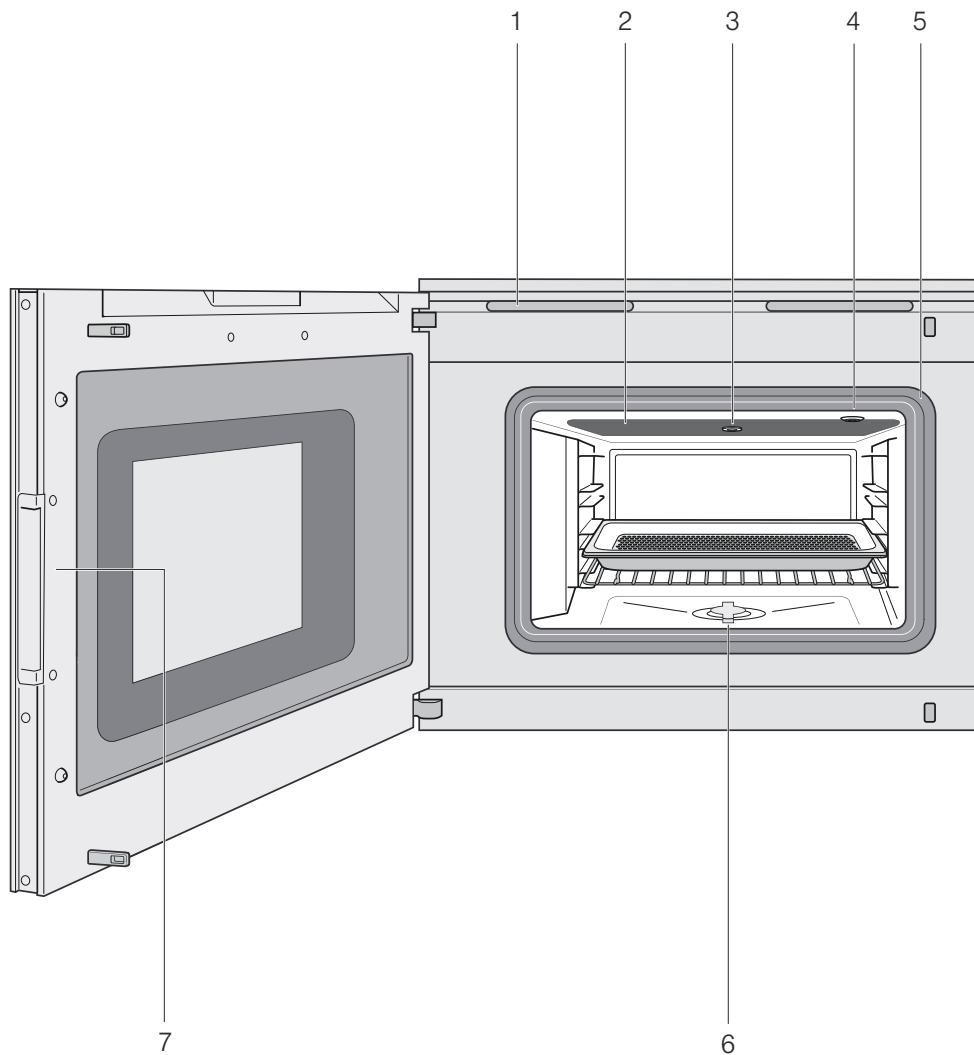

- 
- |   |   |
|---|---|
| 1 | Ventilation slots                           |
| 2 | Glass ceramic grilling surface              |
| 3 | Socket for cleaning and descaling cartridge |
| 4 | Slot for core temperature sensor            |
| 5 | Door seal                                   |
| 6 | Drain filter                                |
| 7 | Recessed handle                             |
-

## Display and operating controls

These instructions are valid for different versions of the appliance. Depending on the appliance model, some details may differ.

All versions of the appliance are operated in an identical manner.

### Operating controls on the upper side of the appliance

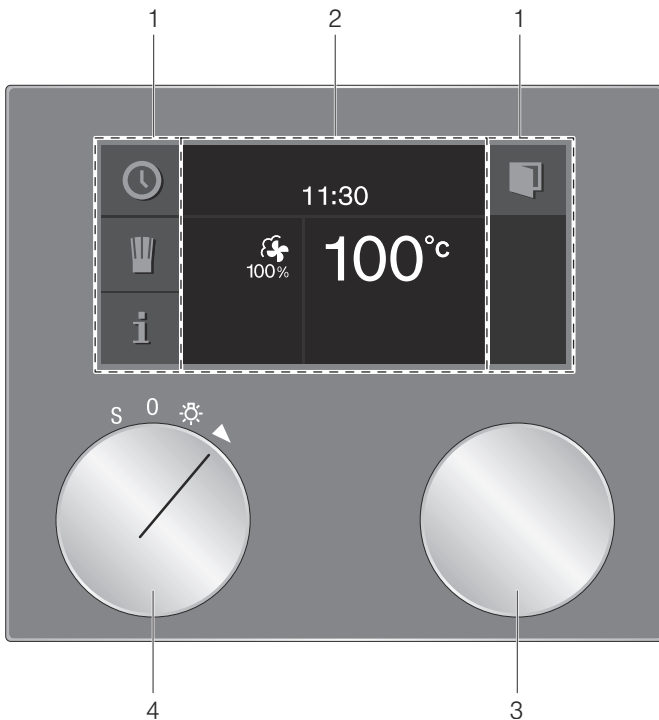

### Operating controls on the lower side of the appliance

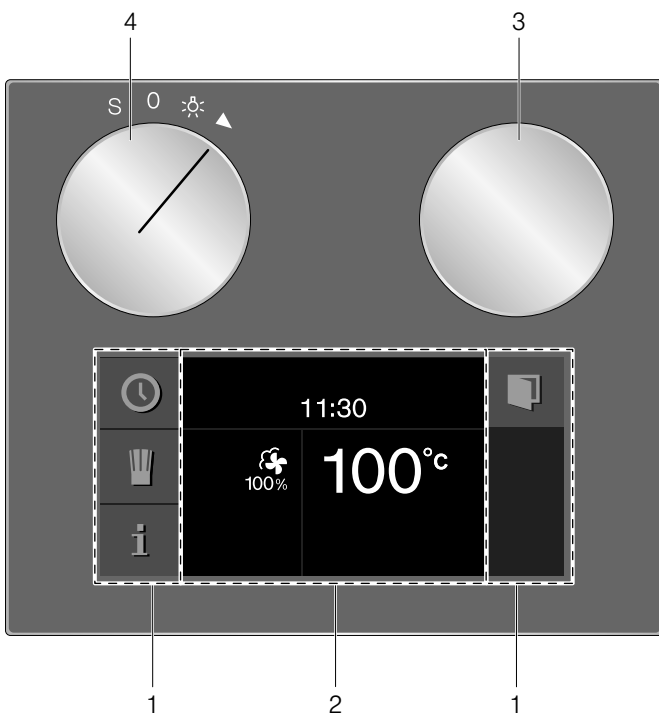

1	Control panel	These areas are touch sensitive. Touch a symbol to select the corresponding function.
2	Display	The display shows, for example, current settings and options.
3	Rotary selector	You can use the rotary selector to set the temperature and to make further settings.
4	Function selector	The function selector is used to select the type of heating, the cleaning function or the basic settings.

## Symbols

Symbol	Function
▶	Start
■	Stop
	Pause/End
x	Cancel
C	Delete
✓	Confirm/save settings
>	Selection arrow
🔒	Open appliance door
i	Call up additional information
⤴	Heating up with status indicator
🍷	Call up individual recipes
rec ●	Record menu
↵	Edit settings
>A*	Enter name
⏪x	Delete letters
🔒	Child lock
🕒	Call up timer menu
🕒	Call up long-term timer
🔧	Demo mode
🌡️	Call up core temperature probe
💧	Misting
🌫️	Steam removal start
🌫️	Steam removal stop



## Colours and display

### Colours

The different colours are used to guide the user in the relevant setting situations.

Orange	Initial settings Main functions
Blue	Basic settings Cleaning
White	Values which can be set

### Display

The appearance of the symbols, values or the entire display changes depending on the situation.

Zoom	The setting which is currently being changed is displayed in an enlarged format.  A cooking time that is coming to an end is shown in an enlarged format shortly before running out (e.g. the last 60 seconds of the timer).
Reduced display	After a short time, the display is reduced and only the most important information is displayed. This function is preset and can be changed in the basic settings.

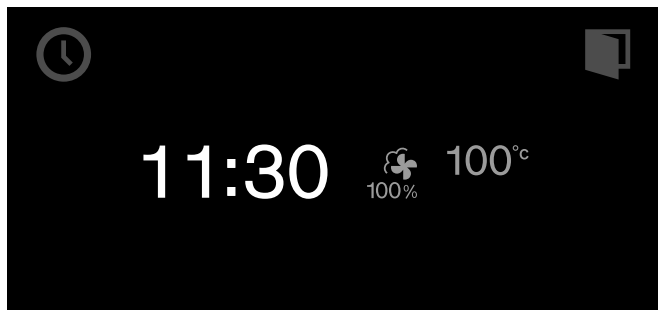

## Automatic door opening

The appliance door springs open when you touch the  symbol and you can open it fully by using the recessed handle on the side.

Automatic door opening does not work if the child lock is activated or there is a power cut. You can open the recessed handle on the side by hand.

## Additional information **i** and **i**<sup>Ⓞ</sup>

By touching the **i** symbol, you can call up additional information. For example, information on the heating function set or on the current temperature of the cooking compartment.

**Note:** During continuous operation, small fluctuations in temperature are normal after the oven has heated up.

The **i**<sup>Ⓞ</sup> symbol is displayed for important information and action prompts. Important information on safety and operation mode are occasionally shown automatically. These messages either disappear automatically after a few seconds or must be confirmed with .

## Cooling fan

Your appliance has a cooling fan. The cooling fan switches on during operation. Depending on the appliance version, the hot air escapes above or under the door.









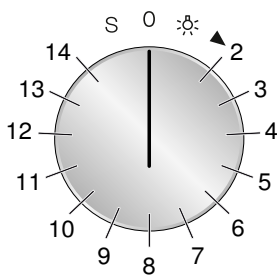

After removing cooked food, keep the door closed until the appliance cools down. The appliance door must not be left ajar, as adjoining kitchen furniture may be damaged. The cooling fan continues to run for a certain time after operation and then switches off automatically.

### Caution!









Do not cover the ventilation slots. Otherwise, the appliance will overheat.

## Function selector positions



Position	Function/heating function	Temperature	Use
0	Off position		
☀	Light		
2	 100% Hot air + 100% humidity	30 - 230 °C Default temperature 100 °C	Steaming at 70 °C - 100 °C: For vegetables, fish and side dishes. The food is completely surrounded by steam 'Combination' mode at 120 - 230 °C: For puff pastry, bread and bread rolls. Hot air and steam are combined.
3	 80% Hot air + 80% humidity	30 - 230 °C Default temperature 170 °C	Combination mode: For puff pastry, meat and poultry. Hot air and steam are combined.
4	 60% Hot air + 60% humidity	30 - 230 °C Default temperature 170 °C	Combination mode: For yeast-risen dough and bread. Hot air and steam are combined. Dough proving, allowing dough to rise: For yeast dough and sourdough. Dough will rise considerably more quickly than at room temperature. Hot air and steam are combined so that the surface of the dough does not dry out. The optimal temperature setting for yeast dough is 38 °C.
5	 30% Hot air + 30% humidity	30 - 230 °C Default temperature 170 °C	Cooking without added liquid: For pastries With this setting, no steam is generated and the ventilation flap is closed. Any steam escaping from the food therefore remains in the cooking compartment and prevents the food from drying out.
6	 0% Hot air and 0% humidity*	30 - 230 °C Default temperature 170 °C	Hot air: For cakes, biscuits and bakes. The fan in the back panel of the oven distributes the heat evenly throughout the cooking compartment.
7	 Low temperature cooking	30 - 90 °C Default temperature 70 °C	Low temperature cooking for meat. Gentle, slow cooking for a particularly tender result.
8	 100% Sous-vide cooking	50 - 95 °C Default temperature 60 °C	Cooking under a vacuum at low temperatures between 50 and 95 °C and 100% steam: Suitable for meat, fish, vegetables and desserts. A vacuum-packing machine is used to heat-seal the food in a special air-tight, heat-resistant cooking bag. The protective envelope retains the nutrients and flavours.
9	 Full surface grill + circulated air	30 - 230 °C Default temperature 230 °C	For vegetable skewers and prawn skewers.
10	 Full surface grill	30 - 230 °C Default temperature 230 °C	For grilled vegetables, browning (e.g. cakes with meringue) and toast with topping.
11	 1 Full surface grill level 1 + humidity	30 - 230 °C Default temperature 170 °C	Grill mode with humidity: For bakes and gratins.

\* Type of heating used to determine the energy efficiency class in accordance with EN 60350-1.

Position	Function/heating function	Temperature	Use
12	 Full surface grill level 2 + humidity	30 - 230 °C Default temperature 170 °C	Grill mode with humidity: For stuffed vegetables. The grill output is increased.
13	 Defrosting	40 - 60 °C Default temperature 45 °C	For vegetables, meat, fish and fruit. The moisture gently transfers the heat to the food. The food does not dry out or lose its shape.
14	 Reheating	60 - 180 °C Default temperature 120 °C	For cooked food and baked goods. Cooked food is gently reheated. The steam ensures that the food does not dry out. Reheat plated meals at 120 °C and baked goods at 180 °C.
S	 Basic settings		Your appliance can be individually adjusted in the basic settings.
	 Cleaning programme		The cleaning programme can be used to remove stubborn dirt from the cooking compartment.
	 Drying programme		The drying programme dries the cooking compartment after steaming or cleaning.
	 Descaling programme		The descaling programme can be used to remove limescale from the cooking compartment.
	 Water filter change		Change the water filter if a descaling system is installed.
	 Delete the descaling hint		Delete the message on the display after descaling.

\* Type of heating used to determine the energy efficiency class in accordance with EN 60350-1.

## Accessories

Use only the accessories supplied with the product or available from the after-sales service. They are specially designed for your appliance. Ensure that you always insert the accessories into the cooking compartment the right way round.

Your appliance is equipped with the following accessories:



**Wire rack**  
for cookware, cake tins and casseroles and for roasts

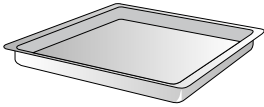

**Stainless steel cooking container, unperforated, GN 2/3, 40 mm deep**  
for cooking rice, pulses and cereals, for baking cake baked on trays and for collecting dripping liquid during steaming

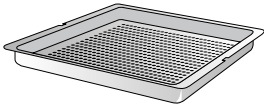

**Stainless steel cooking container, perforated, GN 2/3, 40 mm deep**  
for steaming vegetables or fish, for extracting juice and for defrosting

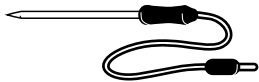

**Core temperature probe**  
for precise preparation of meat, fish, poultry and bread

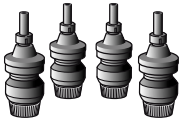

**Set with 4 cleaning cartridges**

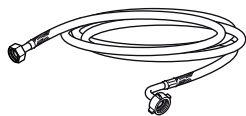

**Water inlet hose, 3 m**

**Outlet hose, 3 m**

## Special accessories

You can order the following special accessories from your specialist dealer:

- BA 476 310 Handle, stainless steel for BS 470/471/474/475
- BA 478 310 Handle, stainless steel for BS 484/485
- CL S10 040 Set with 4 cleaning cartridges
- CL S20 040 Set with 4 descaling cartridges
- GF 111 100 Descaling and neutralising filter (filter head with filter for first installation)
- GF 121 110 Filter cartridge for descaling and neutralising filter
- GN 114 130 Stainless steel cooking container GN 1/3, perforated, 40 mm deep, 1.5 l
- GN 114 230 Stainless steel cooking container GN 2/3, unperforated, 40 mm deep, 3 l
- GN 124 130 Stainless steel cooking container GN 1/3, perforated, 40 mm deep, 1.5 l
- GN 124 230 Stainless steel cooking container GN 2/3, perforated, 40 mm deep, 3 l
- GN 144 130 GN 1/3 cooking insert, non-stick, unperforated, depth: 40 mm, 1.5 l
- GN 144 230 GN 2/3 cooking insert, non-stick, unperforated, depth: 40 mm, 3 l
- GN 154 130 GN 1/3 cooking insert, non-stick, perforated, depth: 40 mm, 1.5 l
- GN 154 230 GN 2/3 cooking insert, non-stick, perforated, depth: 40 mm, 3 l
- GN 340 230 Cast aluminium roaster GN 2/3, 165 mm high, non-stick coated
- GN 410 130 Stainless steel lid, GN 1/3
- GN 410 230 Stainless steel lid, GN 2/3
- GR 220 046 Wire rack, chrome-plated, with feet
- GZ 010 011 Inlet and outlet hose extension, 2 m

Only use the accessories as specified. The manufacturer accepts no liability if these accessories are used incorrectly.

## Before using for the first time

In this section, you can find out what you must do before using your appliance to prepare food for the first time. Read the section entitled 'Important safety information' beforehand.

The appliance must be fully installed and connected to the mains.

After connection to the mains, the "Initial settings" menu appears in the display. You can now make settings for your new appliance.

- Language
- Time format
- Time
- Date format
- Date
- Temperature format
- Water hardness

### Notes

- The "Initial settings" menu will appear only after the appliance has been connected to a power supply and switched on for the first time, or if the appliance has not been connected to a power supply for a number of days. Once the appliance has been connected to a power supply, the GAGGENAU logo will appear first for approximately 30 seconds. The "Initial settings" menu will then appear automatically.
- You can change the settings at any time (see section entitled 'Basic settings').

## Setting the language

The preset language appears in the display.

- 1 Turn the rotary selector to select the required display language.
- 2 Confirm with ✓.

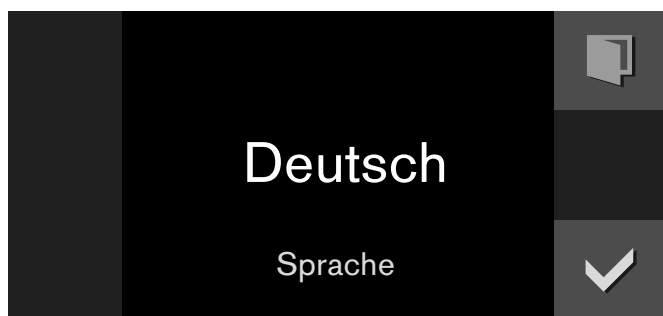

**Note:** If the language is changed, the system restarts. This takes a few seconds.

## Setting the time format

The two possible formats 24h and AM/PM appear in the display. The default is the 24h format.

- 1 Use the rotary selector to select the desired format.
- 2 Confirm with ✓.

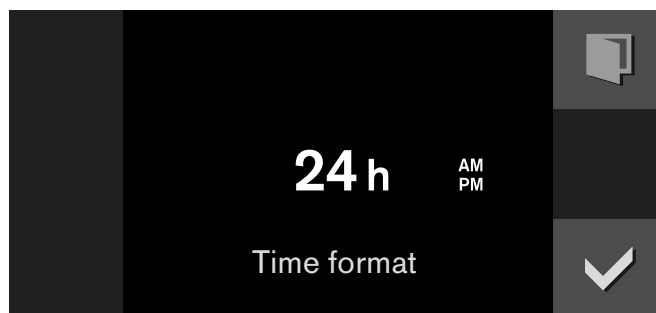

## Setting the clock

The time is shown in the display.

- 1 Set the desired time using the rotary selector.
- 2 Confirm with ✓.

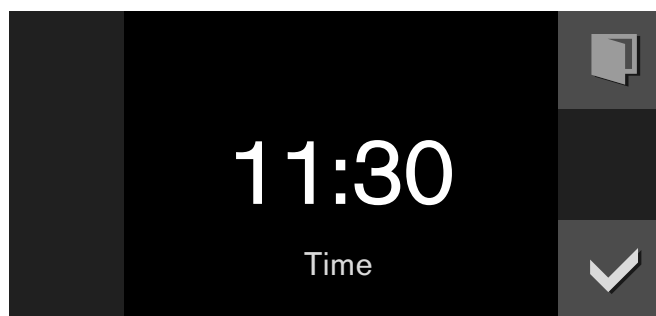

## Setting the date format

The three possible formats D.M.Y, D/M/Y and M/D/Y appear in the display. The default is the D.M.Y format.

- 1 Use the rotary selector to select the desired format.
- 2 Confirm with ✓.

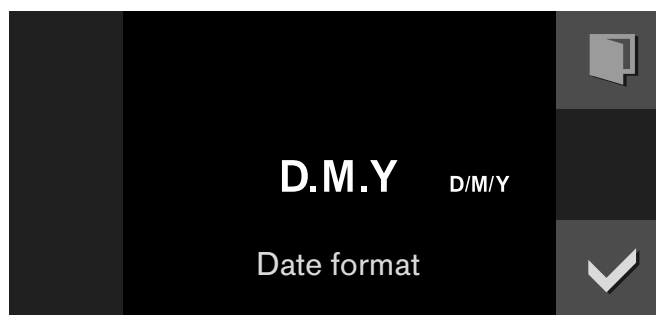

## Setting the date

The preset date appears in the display. The day setting is already active.

- 1 Set the day using the rotary selector.
- 2 Touch the > symbol to switch to the month setting.
- 3 Set the month using the rotary selector.
- 4 Touch the > symbol to switch to the year setting.
- 5 Set the year using the rotary selector.
- 6 Confirm with ✓.

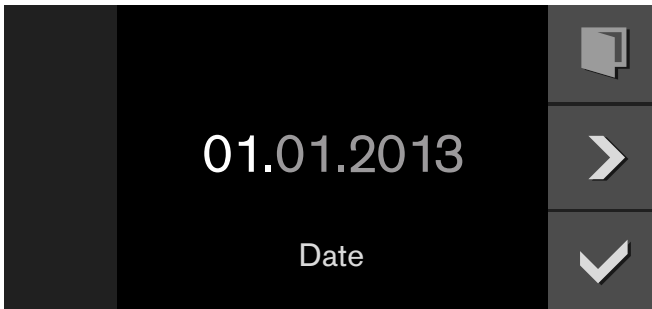

## Setting the temperature format

The two possible formats °C and °F appear in the display. The default setting is °C.

- 1 Use the rotary selector to select the desired format.
- 2 Confirm with ✓.

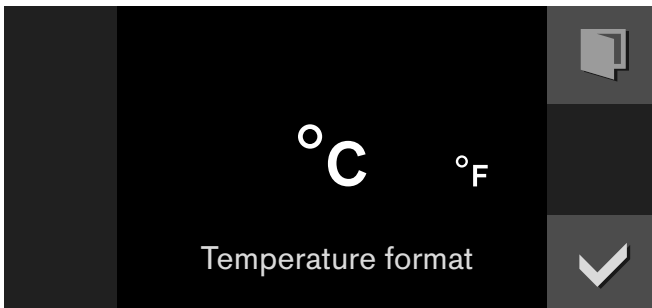

## Setting the water filter

"Water filter" appears in the display. The default is "Available".

It is recommended to install the descaling system GF 111 100 if the water hardness exceeds 7° dH (carbonate hardness 5° dH).

- 1 Use the rotary selector to select "Available" (with water filter) or "Not available" (without water filter).
- 2 Confirm with ✓.
- 3 If water filter "Available" has been selected: "Water filter capacity" is shown in the display.
- 4 Turn the rotary selector to select the capacity of the filter cartridge (between 100 - 9000 litres). Refer to the instructions included with the filter cartridge.
- 5 Confirm with ✓.

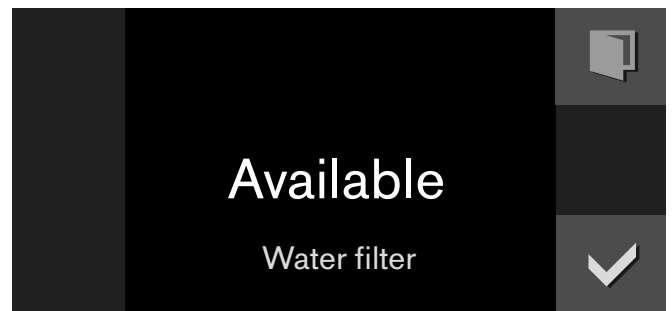

## Setting the water hardness

"Water hardness" appears in the display.

- 1 Check the mains water with the included carbonate hardness test: fill the small measurement tube with mains water up to the 5 ml mark.
- 2 Add drops of indicator solution until the color changes from purple to yellow.  
**Important:** count the drops and carefully swing the measurement tube after every drop until the liquids have mixed thoroughly. The number of drops corresponds to the water hardness.
- 3 Use the rotary selector to set the measured water hardness. The value 12 is set by default.
- 4 Confirm with ✓.

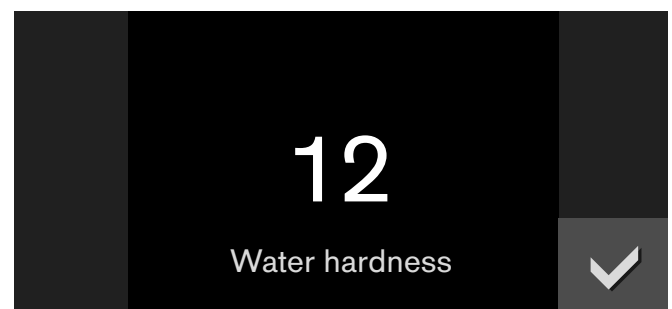

## Ending initial set-up

"Initial set-up complete. Please calibrate the appliance before first cooking." appears in the display.

Confirm with ✓.

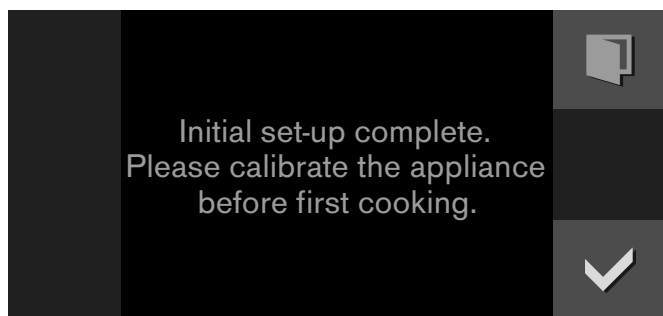

The appliance enters standby mode and the standby screen appears. The appliance is now ready for operation.

Calibrate the appliance before steaming for the first time. The appliance sets the boiling point.

## Calibration

The boiling point of water depends on barometric pressure. As air pressure drops with increasing elevation, the boiling point drops as well. During calibration, the appliance sets the boiling point to the pressure conditions at the place where it is installed.

It is important that the appliance steams without interruption for 20 minutes at 100°C. Do not open the appliance door during this time.

### Notes

- Calibrate the appliance only when it is cold.
  - During calibration, the appliance generates more steam than it normally would do.
- 1 Turn the function selector to **S**.
  - 2 Select "Basic settings" using the rotary selector.
  - 3 Touch the ✓ symbol.
  - 4 Select "Calibration" using the rotary selector.
  - 5 Touch the ↘ symbol.
  - 6 Remove all accessories from the oven interior and touch the ✓ symbol.
  - 7 The duration of 20:00 minutes appears. Touch ▶ to start calibration.

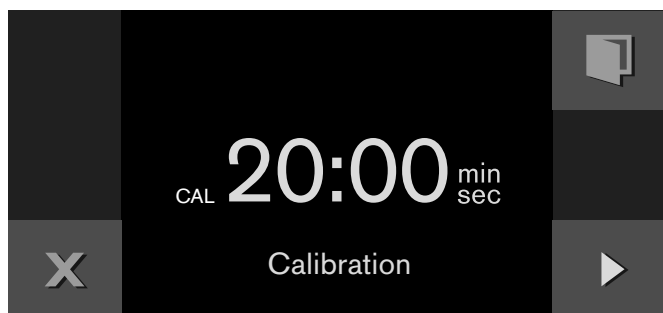

Calibration begins. The elapsing time is shown on the display.

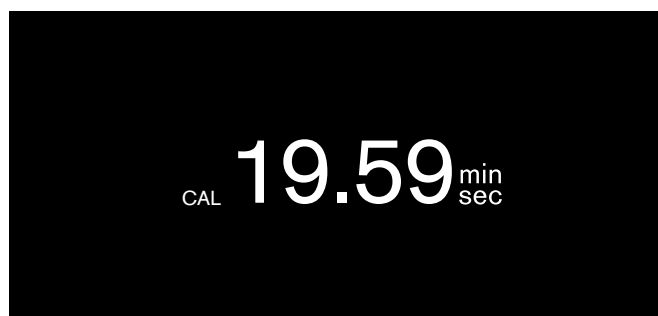

**Note:** Do not interrupt calibration. Do not turn the function selector. Do not open the appliance door.

A message appears in the display once calibration has ended. Touch ✓ to confirm and turn the function selector to **0**.

### After moving house

Repeat calibration so that the appliance adapts automatically to the new installation location.

### After resetting to the factory settings

After resetting to the factory settings in the basic settings menu, you must repeat calibration.

### Following a power cut

The appliance saves the calibration settings even in the event of a power cut or disconnection from the mains. Recalibration is not necessary.

## Cleaning accessories

Before using the accessories for the first time, clean them thoroughly using hot detergent solution and a soft cloth.

---

## Water filter

---

### Operation with or without a water filter

You can use the appliance with or without a water filter.

If the water hardness exceeds 7° dH or carbonate hardness 5° dH, we recommend the installation of the descaling system GF 111 100.

### Changing the water filter

Filter cartridges should be replaced regularly. Replacement cartridges are available from after-sales service or in the online shop (order number GF 121 110).

The capacity of the filter cartridge depends on the frequency of use of the appliance and your regional water hardness. A message will appear in the display to remind you when the filter needs to be replaced. Regardless of the actual amount of water filtered the filter cartridge needs to be changed after 12 months at the latest.

- 1 Set the function selector to **S**. Select "Water filter change" using the rotary selector.
- 2 The 🕒 symbol is displayed. Confirm with ✓.
- 3 Change the water filter cartridge. Refer to the instructions included with the filter cartridge. Confirm with ✓.
- 4 "Water filter capacity" is shown in the display. Confirm with ✓.
- 5 Turn the rotary selector to select the capacity of the filter cartridge (between 100 - 9000 litres). Confirm with ✓.

The water filter change is complete. Confirm with ✓.  
The appliance is now ready for operation.

---

## Activating the appliance

---

### Standby

The appliance goes into standby mode if no function has been set or the child lock is activated.

The brightness of the control panel is dimmed in standby mode.

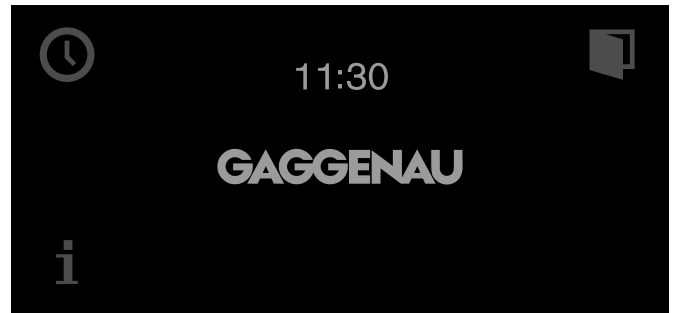

#### Notes

- Different displays are available for standby mode. The default setting is the GAGGENAU logo and the clock. To change the display, refer to the Basic settings section.
- The brightness of the display depends on the vertical viewing angle. You can adjust the display using the "Brightness" setting in the basic settings.

### Activating the appliance

To exit standby mode, you can either

- Turn the function selector,
- Touch a control panel,
- Open or close the door.

You can now set the desired function. You can read about how to set functions in the respective chapters.

#### Notes

- When "Standby screen = off" is selected in the basic settings, you must turn the function selector to exit standby mode.
- The appliance returns to the standby screen if you have not made any settings for a long time after activation.
- When the door is open, the interior lighting switches off after a short time.



## Operating the appliance

### Cooking compartment

The cooking compartment has four rack levels. The rack levels are counted from the bottom up.

**Note:** When steaming, defrosting, dough proving and reheating, you can use up to three rack levels at a time (levels 2, 3 and 4). Only one level can be used for baking; level 2 is designated for this (or level 1 for high baking tins).

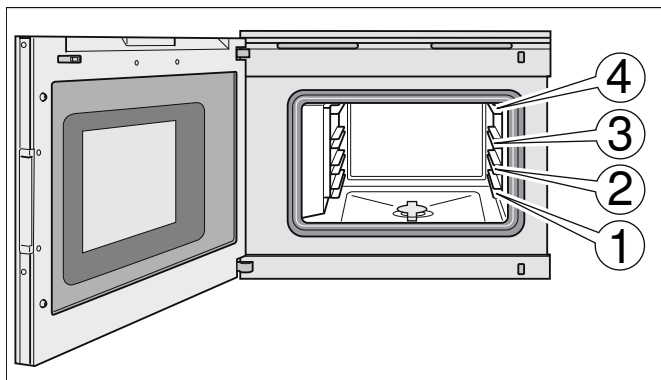

#### Caution!

- Do not place anything directly on the cooking compartment floor. Do not cover it with aluminium foil. A build-up of heat could damage the appliance. The cooking compartment floor must always be kept clear. Always place cookware in the perforated cooking container or on the wire rack.
- Do not slide any accessories between the shelf positions, or they may tip.

### Inserting accessories

The wire rack and the perforated cooking container feature a locking function. The locking function prevents the accessories from tilting when they are pulled out. The accessories must be inserted into the cooking compartment correctly for the tilt protection to work properly. When removing accessories, you must raise them slightly.

When inserting the wire rack, check

- that the engaging lug (a) is pointing upward
- that the safety bar on the wire rack is at the back and facing upwards.

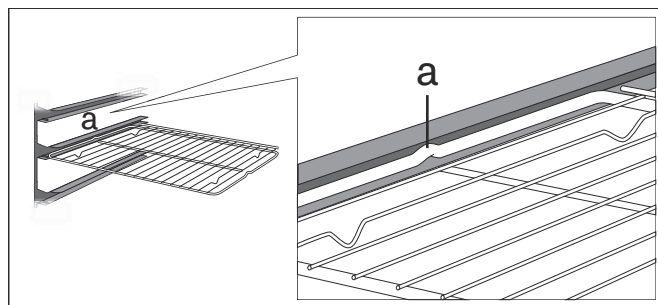

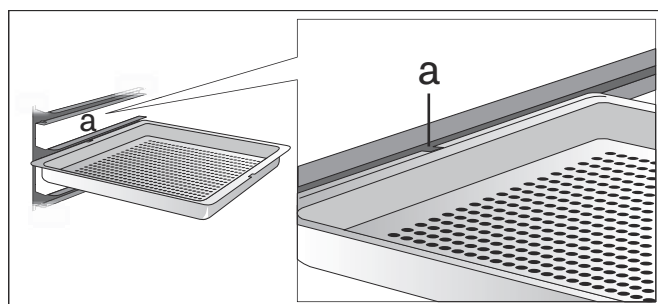

When pushing in the perforated cooking container, make sure that the recess (a) is pointing to the side.



## Switching on

- 1 Use the function selector to set the required type of heating. The selected type of heating and the default temperature are shown on the display.
- 2 If you wish to change the temperature:  
Turn the rotary selector to set the required temperature.

The heat-up symbol  will appear on the display. The bar shows the current heat-up status. When the set temperature has been reached, an audible signal will sound and the heat-up symbol  will go out.

### Notes

- If the temperature is set to less than 70 °C, the cooking compartment light will remain switched off.
- If the type of heating is set to "Sous-vide cooking", the cooking compartment light will remain switched off.
- The temperature that has been set will be retained when you change to a different operating mode. The default temperature will not appear until the appliance has been switched on.

### Switching off:



Turn the function selector to **0**.

## Misting

Misting brings additional steam to the oven interior. You can add moisture to food while cooking (e.g. bread, bread rolls).

Misting is only possible with these heating functions:

- Hot air + 30% humidity
- Hot air + 0% humidity
- Full surface grill + circulated air
- Full surface grill

Touch the  symbol as long as you want to add steam, up to 8 seconds. After waiting at least one second, you can trigger misting again by touching the  symbol.

## Steam removal

During the steam removal process, cold water is introduced into the cooking compartment. This cools the cooking compartment down and the steam condenses on the cooking compartment wall. When you then open the cooking compartment door, only a little steam escapes.

### Risk of scalding!

After opening the cooking compartment door, hot water may drip down from it.

Steam removal only works with the following types of heating and if the temperature in the cooking compartment is less than 130 °C:

- Hot air + 100% humidity
- Hot air + 80% humidity
- Hot air + 60% humidity
- Full surface grill setting 1 + humidity
- Full surface grill setting 2 + humidity
- Sous-vide cooking

### Proceed as follows:

Touch the  symbol. Steam removal takes approximately 20 seconds. During this time, the heating is off.

### Stopping steam removal early:

Open the door or touch the  symbol

**Note:** The steam removal function is also available for a short time after switching off the appliance.

## After every use

- 1 Remove food remnants from the cooking compartment surfaces as soon as the appliance has cooled down. Burnt-on remnants will be much harder to remove later.
- 2 Once the cooking compartment has cooled down, wipe it down and dry it thoroughly with a soft cloth.
- 3 Wipe units and handles dry where condensation has formed.
- 4 Use the drying programme to dry the cooking compartment (see section entitled 'Drying programme') or leave the appliance door open until the cooking compartment is completely dry.

## Safety shut-off

For your protection, the appliance is equipped with an automatic safety shut-off. Any heating process is switched off after 12 hours if the oven is not operated in this time. A message appears in the display.

Exception:

The long-term timer has been programmed.

Set the function selector to **0**, then the appliance can be operated again as usual.

## Timer functions

You use the timer menu to make the following settings:

- ⌚ Short-term timer
- ⌚ Stopwatch
- 🕒 Cooking time (not in standby mode)
- 🕒 Cooking time end (not in standby mode)

### Calling up the timer menu

You can call up the timer menu from any mode. Only from the basic settings, function selector is set to **S**, the timer menu is not available.

Touch the 🕒 symbol.

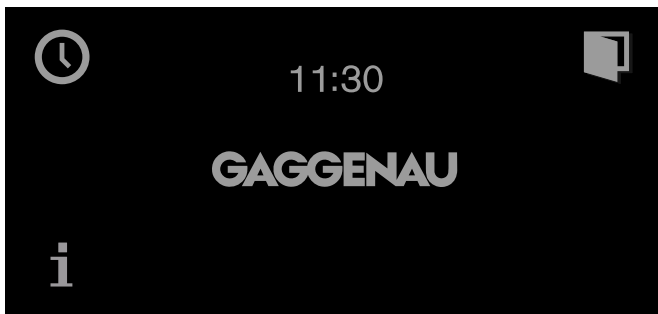

The timer menu is displayed.

### Timer

The timer runs independently of the other appliance functions. You can enter a maximum of 90 minutes.

#### Setting the timer

- 1 Call up timer menu.  
The "Timer" ⌚ function is displayed.
- 2 Turn the rotary selector to set the required cooking time.

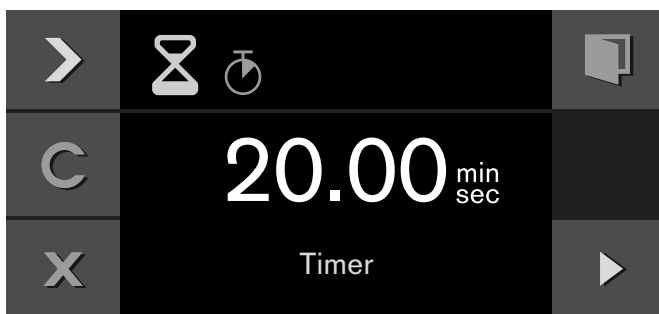

- 3 Start with ▶.

The timer menu closes and the time begins to count down. The ⌚ symbol and the countdown appear in the display.

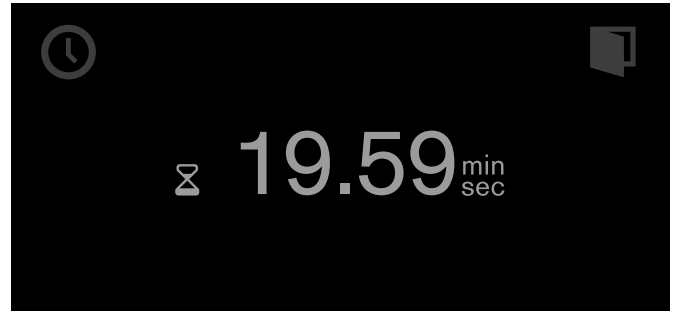

A signal sounds once the time has elapsed. Touch the ✓ symbol to silence.

You can exit the timer menu at any time by touching the X symbol. This erases the settings.

#### To stop the timer:

Call up timer menu. Touch ▶ to select the "Timer" ⌚ function and touch the || symbol. To allow the timer to continue counting down, touch the ▶ symbol.

#### Switching off the timer early:

Call up timer menu. Touch ▶ to select the "Timer" ⌚ function and touch the C symbol.

### Stopwatch

The stopwatch runs independently of the other appliance functions.

The stopwatch counts from 0 seconds up to 90 minutes.

It also has a pause function, which enables you to temporarily stop the clock.

#### Starting the stopwatch

- 1 Call up the "Timer" menu.
- 2 Touch ▶ to select the ⌚ "Stopwatch" function.

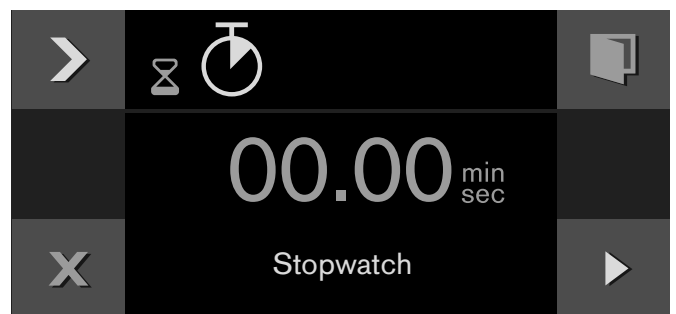

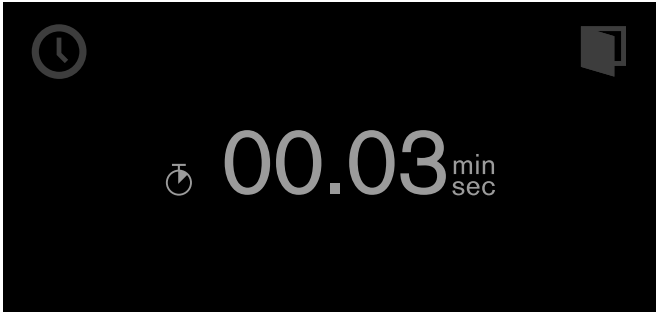

- 3 Press ▶ to start.

The "Timer" menu is closed and the time starts counting down. The  symbol and the elapsed time are shown in the display.



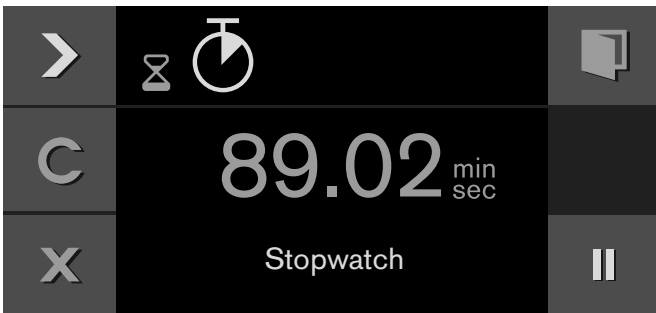

### Pausing and restarting the stopwatch

- 1 Call up the "Timer" menu.
- 2 Touch  to select the  "Stopwatch" function.
- 3 Touch the  symbol.





The time stops. The symbol changes to  "Start".

- 4 Press  to start.

The time continues to run. When 90 minutes is reached, the display pulsates and a signal sounds. The signal stops when you touch the  symbol. The  symbol in the display goes out. The process has finished.

### To switch off the stopwatch:

Call up the "Timer" menu. Touch  to select the  "Stopwatch" function and touch the  symbol.



## Cooking time

If you set a cooking time for your meal, the appliance switches off heating automatically after the selected time.

You can set a cooking time from 1 minute to 23 hours 59 minutes.

### Setting a cooking time

You have set the heating mode and temperature and you have placed your dish in the oven.

- 1 Touch the  symbol.
- 2 Use  to select the  "Cooking time" function.

- 3 Set the desired cooking time using the rotary selector.



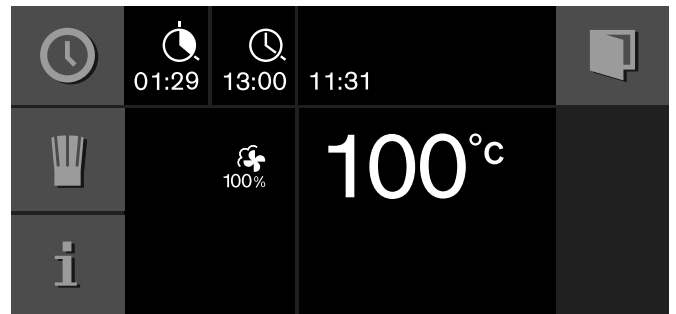

- 4 Press  to start.

The appliance starts. The timer menu is closed. The settings for temperature, heating mode, elapsing time and cooking time end are shown in the display.



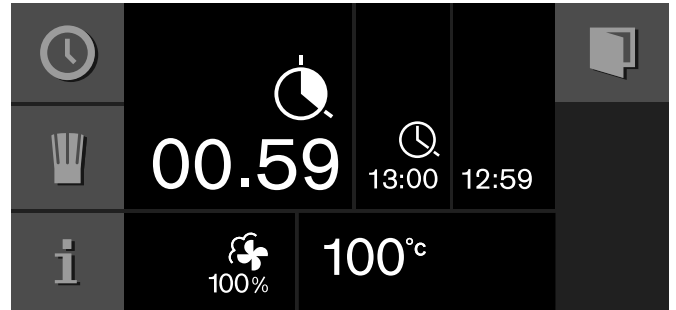

During the last minute of the cooking time the remaining time is displayed in an enlarged format.







The appliance switches off after the cooking time has elapsed. The  symbol flashes and a signal sounds. The signal stops when you touch the  symbol, open the appliance door, or switch the function selector to **0**.

### Changing the cooking time:

Call up the timer menu. Use  to select the  "Cooking time" function. Change the cooking time using the rotary selector. Press  to start.

### Clearing the cooking time:

Call up the timer menu. Use  to select the  "Cooking time" function. Clear the cooking time with . Return to normal operation with .

### Cancelling the entire operation:

Set the function selector to **0**.

**Note:** You can also change the heating mode and temperature during the cooking time.

## End of cooking time

You can delay the cooking time end to a later time.

Example: it is 14:00. The dish requires a cooking time of 40 minutes. You want it to be ready at 15:30.

Enter the cooking time and delay the cooking time end until 15:30. The electronics system calculates the start time. The appliance starts automatically at 14:50 and switches off at 15:30.

Bear in mind that food which spoils easily should not be left in the cooking compartment for too long.

### Delaying the cooking time end

You have set the heating mode, temperature and cooking time.

- 1 Touch the ⌚ symbol.
- 2 Use ➤ to select the ⌚ "Cooking time end" function.



- 3 Set the desired cooking time end using the rotary selector.
- 4 Press ▶ to start.

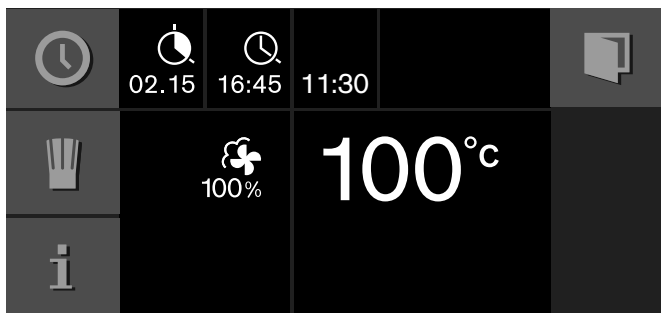

The appliance switches to standby. The heating mode, temperature, cooking time and cooking time end appear in the display. The appliance starts at the calculated time and switches off automatically when the cooking time has elapsed.

**Note:** If the ⌚ symbol flashes: You have not set the cooking time. Always set the cooking time first.

Once the cooking time has elapsed, the appliance switches off. The ⌚ symbol flashes and an audible signal sounds. The signal stops early if you touch the ✓ symbol, open the appliance door, or set the function selector to 0.

### To change the cooking time end:

Call up the timer menu. Use ➤ to select the ⌚ "Cooking time end" function. Set the desired cooking time end using the rotary selector. Press ▶ to start.

### To terminate the whole procedure:

Set the function selector to 0.

---

## Long-term timer

---

With this function, the appliance maintains a temperature between 50 und 230°C with the "Hot air" heating function.

You can keep food warm for up to 74 hours without having to switch the appliance on or off.

Bear in mind that food which spoils easily should not be left in the oven for too long.

**Note:** You must set the long-term timer to "available" in the basic settings (refer to the Basic settings section).

### Setting the long-term timer

- 1 Set the function selector to ☼.
- 2 Touch the ⌚ symbol.  
The default value 24 hrs at 85 °C appears in the display. Press ▶ to start  
–or–  
Change the cooking time, the cooking time end and the switch-off date.

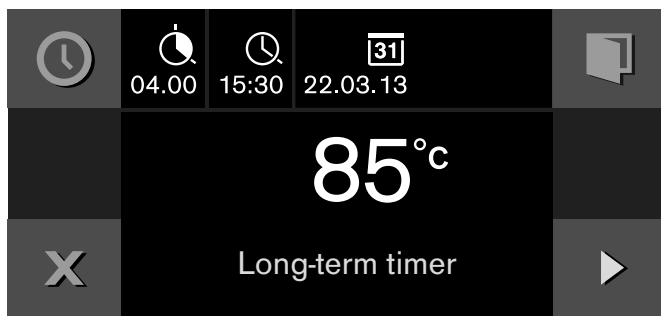

- 3 Changing the cooking time ⌚:  
Touch the ⌚ symbol. Set the required cooking time using the rotary selector.
- 4 Changing the cooking time end ⌚:  
Touch the ➤ symbol. Set the required cooking time end using the rotary selector.
- 5 Changing the switch-off date [31]:  
Touch the ➤ symbol. Set the required switch-off date with the rotary selector. Confirm with ✓.
- 6 Changing the temperature:  
Set the required temperature with the rotary selector.
- 7 Press ▶ to start.

The appliance starts. ⌚ and the temperature appear in the display.

The oven and display lighting are switched off. The control panel is locked; no key tone sounds when you touch the touch keys.

Once the set time has elapsed, the appliance stops heating. Turn the function selector to 0.

#### Switching off:

To end the process, turn the function selector to 0.

---

## Individual recipes

---

It is possible to save up to 50 individual recipes. You can record a recipe. These recipes can be given a name so that they can be called up quickly and conveniently when required.

### Recording a recipe

It is possible to consecutively set up to 5 phases and to record at the same time.

- 1 Select the required heating mode using the function selector.  
The 🍷 symbol is displayed.
- 2 Touch the 🍷 symbol.
- 3 Select a free memory location by turning the rotary selector.
- 4 Touch the <sup>rec</sup>● symbol.

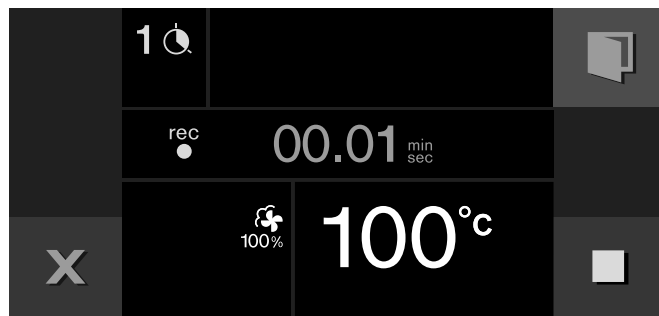

- 5 Select the required temperature using the rotary selector.
- 6 The cooking time is recorded.
- 7 To record another phase:  
Select the required heating mode using the function selector. Set the temperature using the rotary selector. This begins a new phase.
- 8 If the dish has achieved the desired cooking result, touch the ■ symbol to finish the recipe.
- 9 Enter the name in "ABC" (refer to the Entering names section).

#### Notes





- Recording of a phase starts only once the selected temperature has been reached.
- The minimum duration of each phase is 1 minute.
- During the first minute of a new phase it is possible to change the heating mode or the temperature.

#### Set a core temperature for a phase:





Connect the core temperature probe to the socket in the oven. Set the heating mode and the temperature. Touch the 🍷 symbol. Select the core temperature using the rotary selector and touch 🍷 to confirm.

## Programming a recipe

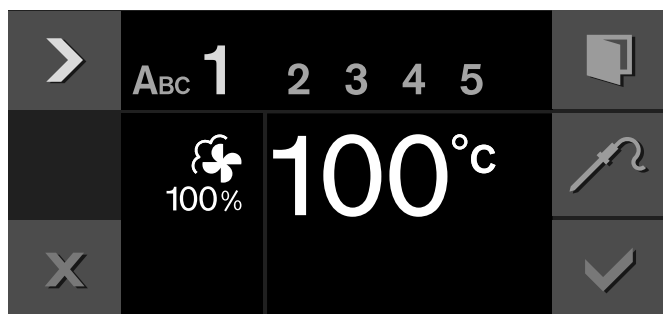

You can programme and save up to 5 preparation phases.

- 1 Turn the function selector to the desired type of heating. Turn the rotary selector to set the desired temperature. The  symbol is displayed.
- 2 Touch the  symbol.
- 3 Select a free memory location by turning the rotary selector.
- 4 Touch the  symbol.
- 5 Enter the name in "ABC" (see the Entering names chapter).
- 6 Use the  symbol to select the first phase. The type of heating and temperature at the beginning is displayed. You can change the type of heating and the temperature by using the rotary selectors.



- 7 Use the  symbol to select the time setting.
- 8 Turn the rotary selector to set the desired cooking time.
- 9 Use the  symbol to select the next phase.  
- or -  
Preparation is complete, finish making entries.
- 10 Save with .  
- or -  
Cancel with  and exit the menu.

### Entering the core temperature for a phase:



Use the  symbol to select the next phase. Setting the type of heating and temperature. Touch the  symbol. Using the rotary selector, enter the desired core temperature and confirm with .

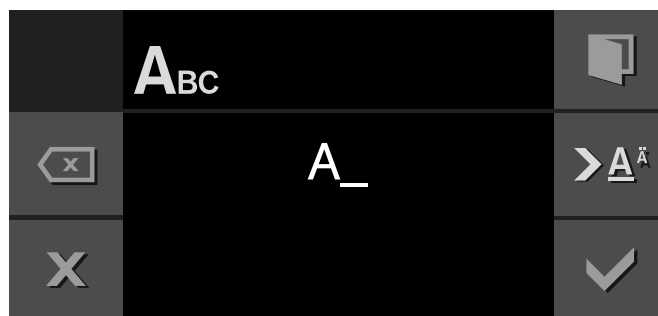

**Note:** No cooking time can be entered for phases with programmed core temperatures.

## Entering names

- 1 Enter the name of the recipe in "ABC".





Rotary selector	Select letters A new word always begins with a capital letter.
	Press briefly: moves the cursor right Press and hold: shifts to umlauts and special characters Press twice: adds a line break
	Press briefly: moves the cursor right Press and hold: shifts to normal characters Press twice: adds a line break
	Deletes letters

- 2 Save with .  
- or -  
Cancel with  and exit the menu .

**Note:** For entering a name, Latin characters, certain special characters and numbers are available.

## Starting recipes

- 1 Set the function selector to any heating mode. The  symbol is displayed.
- 2 Touch the  symbol. Use the rotary selector to select the required recipe.
- 3 Press  to start.  
Operation starts. The cooking time starts counting down in the display.  
The settings for each phase are shown in the display.

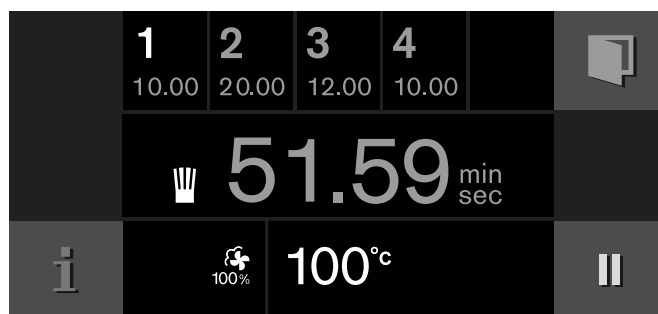







## Notes





- The cooking time does not start counting down until the appliance has reached the set temperature.
- You can use the rotary selector to change the temperature while the recipe is in progress. This does not change the saved recipe.

## Change recipe

You can change the settings of a recorded or programmed recipe.

- 1 Turn the function selector to the any type of heating. The  symbol is displayed.
- 2 Touch the  symbol.
- 3 Use the rotary selector to select the desired recipe.
- 4 Touch the  symbol.
- 5 Use the  symbol to select the desired phase. The programmed type of heating, temperature and cooking time are displayed. You can use the rotary selector or function selector to change the settings.
- 6 Save with .  
- or -  
Cancel with  and exit the menu.

## Deleting recipes

- 1 Set the function selector to any type of heating. The  symbol is displayed.
- 2 Touch the  symbol.
- 3 Use the rotary selector to select the desired recipe.
- 4 Delete the recipe with .
- 5 Confirm with .

---

## Core temperature probe

---

The core temperature probe enables exact cooking to the spot. It measures the temperature inside the food being cooked. Automatic switching off when the desired core temperature is reached ensures that each food is cooked precisely.

Use the included core temperature probe only. You can purchase one as a spare part from after-sales service or in the online shop.

The core temperature probe can be damaged at temperatures above 250°C. Therefore, only ever use it in your oven up to a temperature of 230°C.

Always remove the core temperature probe from the oven after use. Never store it in the oven.

After every use, clean the core temperature probe with a moist cloth. Do not wash it in a dishwasher!

### Risk of electric shock!

The insulation of an incompatible meat probe may be damaged. Only use the meat probe which is recommended for this appliance.

### Risk of burns!

The cooking interior and the core temperature probe become very hot. Use oven mitts to plug and unplug the core temperature probe.



## Inserting the core temperature probe in the food to be cooked

Insert the core temperature probe in the food to be cooked before you place it in the cooking interior.

Insert the metal tip at the thickest point in the food to be cooked. Make sure that the end of the tip is approximately in the centre. It must not be placed in the fat and must not touch any cookware or bones.

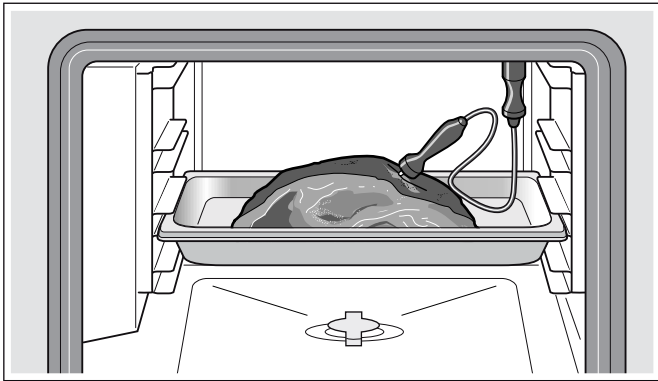



If there are several pieces, insert the core temperature probe in the middle of the thickest piece.

Insert the core temperature probe completely, if possible.

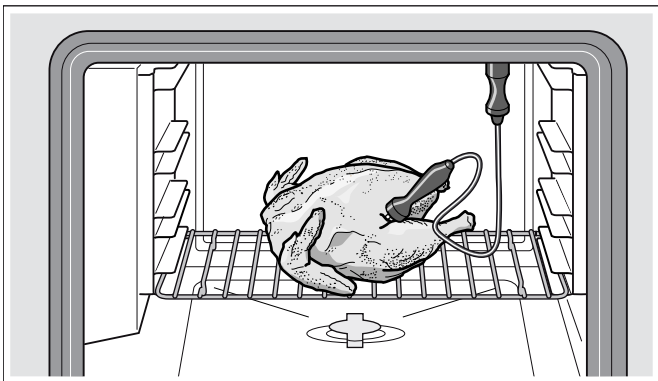
In the case of poultry, make sure that the tip of the core temperature probe is not in the cavity in the centre, but in the meat between the belly and upper leg.



## Setting the core temperature

- 1 Insert food into the oven interior with the core temperature probe inserted. Insert the core temperature probe in the socket in the oven interior and close the appliance door. Do not jam the core temperature probe's cable!
- 2 Set the function selector to the required heating mode.
- 3 Set the oven interior temperature with the rotary selector.
- 4 Touch the  symbol. With the rotary selector, set the required core temperature and confirm it with . The set core temperature must be higher than the current core temperature.

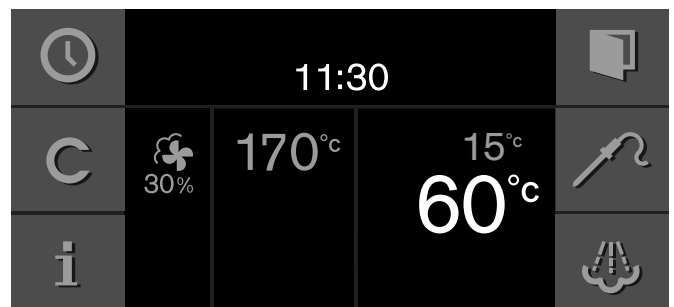



- 5 The appliance heats with the set heating mode. The current core temperature is displayed and, under it, the set core temperature. You can change the set core temperature at any time.

A signal sounds when the set core temperature in the food has been reached. The cooking mode is ended automatically. Confirm with  and turn the function selector to 0.



### Notes

- The measurable range is 15 °C to 99 °C. Outside the measurable area, "--°C" is displayed for the current core temperature.
- If you leave food in the cooking compartment for some time after cooking, the core temperature continues to rise somewhat due to the residual heat in the cooking compartment.
- If you set the core temperature probe and the cooking timer at the same time, the appliance switches off whichever programme reaches the entered value first.

### Changing the set core temperature:

Touch the  symbol. Use the rotary selector to change the set core temperature for the food and confirm with .

### Deleting the set core temperature:

Touch the  symbol. Delete the set core temperature with . The appliance continues heating in normal cooking operation.

## Core temperature guidelines

Use chilled food only, not frozen food. The details given in the table are guidelines. Results depend on the quality and composition of the food.

For hygiene reasons, critical foodstuffs such as fish and game should reach a core temperature of 62 – 70 °C; for poultry and minced meat this should be as high as 80 – 85 °C.

Food	Core temperature guideline
<b>Beef</b>	
Sirloin, tenderloin, entrecôte	
very rare	45 – 47 °C
rare	50 – 52 °C
medium	58 – 60 °C
well-done	70 – 75 °C
Joint of beef	80 – 85 °C
<b>Pork</b>	
Joint of pork	72 – 80 °C
Loin of pork	
medium	65 – 70 °C
well-done	75 °C
Meat loaf	85 °C
Fillet of pork	65 – 70 °C
<b>Veal</b>	
Joint of veal, well-done	75 – 80 °C
Breast of veal, stuffed	75 – 80 °C
Saddle of veal	
medium	58 – 60 °C
well-done	65 – 70 °C
Fillet of veal	
rare	50 – 52 °C
medium	58 – 60 °C
well-done	70 – 75 °C
<b>Game</b>	
Saddle of venison	60 – 70 °C
Leg of roe venison	70 – 75 °C
Venison loin steaks	65 – 70 °C
Saddle of hare or rabbit	65 – 70 °C

Food	Core temperature guideline
<b>Poultry</b>	
Chicken	85 °C
Guinea fowl	75 – 80 °C
Goose, turkey, duck	80 – 85 °C
Duck breast	
medium	55 – 60 °C
well-done	70 – 80 °C
Ostrich steak	60 – 65 °C
<b>Lamb</b>	
Leg of lamb	
medium	60 – 65 °C
well-done	70 – 80 °C
Saddle of lamb	
medium	55 – 60 °C
well-done	65 – 75 °C
<b>Mutton</b>	
Leg of mutton	
medium	70 – 75 °C
well-done	80 – 85 °C
Saddle of mutton	
medium	70 – 75 °C
well-done	80 °C
<b>Fish</b>	
Fillet	62 – 65 °C
Whole	65 °C
Terrine	62 – 65 °C
<b>Miscellaneous</b>	
Bread	90 °C
Paté	72 – 75 °C
Terrine	60 – 70 °C
Foie gras	45 °C

---

## Child lock

---

The appliance has a childproof lock to prevent children operating it accidentally.

### Notes

- You need to set the childproof lock to "available" in the basic settings (see section entitled 'Basic settings').
- If there is a power cut after the childproof lock has been activated, the childproof lock may be off when the power comes back on again.

## Activate the child lock

### Prerequisite:

The function selector is set to **0**.

Touch and hold the  symbol for at least 6 seconds.

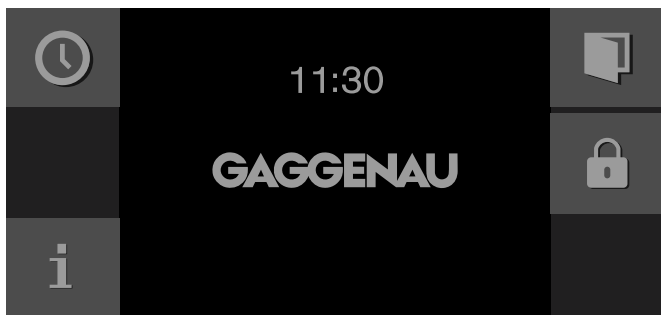

The child lock is activated. The standby screen appears. The  symbol is shown at the top of the display.

## Deactivating the child lock

### Prerequisite:

The function selector is set to **0**.

Touch and hold the  symbol for at least 6 seconds.

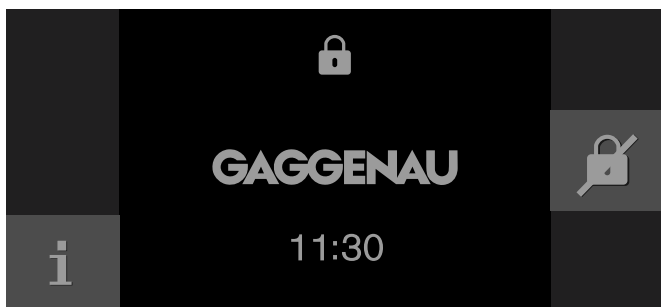

The child lock is deactivated. You can set the appliance as usual.













## Basic settings













Your appliance can be individually adjusted in the basic settings.

- 1 Turn the function selector to **S**.
- 2 Select "Basic settings" using the rotary selector.
- 3 Touch the ✓ symbol.
- 4 Turn the rotary selector to select the required basic setting.

- 5 Touch the \\_ symbol.
- 6 Set the basic setting using the rotary selector.
- 7 Save with ✓ or cancel with X and exit the current basic setting.
- 8 Turn the function selector to **0** to exit the basic settings menu.

The changes are saved.

	Basic setting	Permitted settings	Explanation
	Brightness	Level 1, 2, 3, 4, 5*, 6, 7, 8	Sets the display brightness
	Standby screen	On*/Off - Clock - Clock + GAGGENAU logo* - Date - Date + GAGGENAU logo - Clock + date - Clock + date + GAGGENAU logo	Appearance of the standby screen. Off: No display. Use this setting to reduce the standby consumption of your appliance. On: Several displays can be set, confirm "On" with ✓ and use the rotary selector to select the desired display. The selection is displayed.
	Display	Reduced*/Standard	If the 'Reduced' setting has been selected, only the most important information will be shown on the display after a short time.
	Touch field colour	Grey* / White	Selects the colour of the symbols on the touch fields
	Touch field tone	Tone 1* / Tone 2 / Off	Selects an audible signal for when a touch field is touched
	Touch field tone volume	Level 1, 2, 3, 4, 5*, 6, 7, 8	Sets the volume of the touch field tone
	Preheating signal	On* / Off	The signal tone sounds when the cooking compartment has heated up to the required temperature.
	Signal volume	Level 1, 2, 3, 4, 5*, 6, 7, 8	Sets the volume of the audible signal
	Water filter	Available*/not available	Available: Operating the appliance with a water filter. Not available: Operating the appliance without a water filter.
	Water filter capacity	100 - 9000 litres	Sets the water filter capacity
	Water hardness	1-18	Use the test kit included to test the water hardness of your mains water. Set the measured water hardness.
	Calibration	Calibrate the appliance	Adjusts the boiling point
	Time format	AM/PM / 24 h*	Display the clock in 24 or 12-hour format

	Time	Current time	Setting the clock
	Clock change	Manual* / Automatic	Automatically changes the clock to daylight-savings time. If automatic: Setting the month, day and week for when the time should be changed over. To be set for both summer and winter time.
	Date format	D.M.Y* D/M/Y M/D/Y	Sets the date format
	Date	Current date	Sets the date. You can switch between year/month/day using the symbol ➤.
	Temperature format	°C* / °F	Sets the temperature unit
	Language	German* / French / Italian / Spanish / Portuguese / Dutch / Danish / Swedish / Norwegian / Finnish / Greek / Turkish / Russian / Polish / Czech / Slovenian / Slovakian / Arabic / Hebrew / Japanese / Korean / Thai / Chinese / English US / English	Select language for text display <b>Note:</b> If the language is changed, the system restarts. This takes a few seconds. The basic settings menu is also closed.
	Factory settings	Restore appliance to factory settings	Confirm the question "Delete all individual settings made and reset to factory settings?" by pressing ✓ or cancel by pressing X. <b>Note:</b> Individual recipes will also be deleted if the appliance is restored to factory settings. After restoring factory settings, the "Initial settings" menu is displayed.
	Demo mode	On / Off*	Only for presentation purposes. The appliance does not heat up in demo mode, all other functions are available. The "Off" setting must be activated for normal operation. The setting is only possible in the first 3 minutes after connecting the appliance to the mains.
	Demo cleaning programme	Starts the demo cleaning programme	For presentation purposes only. Does not actually clean or heat. The demo cleaning programme takes 10 minutes. It can be terminated at any time. You will need a new or used standard cleaning cartridge. The appliance must be connected to a water supply and drainage system. Then manually dry the cooking compartment.
	Long-term timer	Not available*/Available	Available: The long-term timer can be set; see section entitled 'Long-term timer'.
	Door lock	Off* / On	The door lock prevents unintentional opening of the appliance door. When "On" is set, you must touch the  symbol for several seconds before the door opens.



Childproof lock

Not available\*/Available

Available: The childproof lock can be activated (see section entitled 'Childproof lock').

\* Factory setting

## Cleaning and maintenance

With thorough care and cleaning your appliance will retain its looks and remain in good order. We will explain here how you should care for and clean your appliance correctly.

### Risk of burns!

The appliance becomes very hot. Never touch the interior surfaces of the cooking compartment or the heating elements. Always allow the appliance to cool down. Keep children at a safe distance.

### Risk of electric shock!

Do not use any high-pressure cleaners or steam cleaners, which can result in an electric shock.

### Risk of injury!

Scratched glass in the appliance door may develop into a crack. Do not use a glass scraper, sharp or abrasive cleaning aids or detergents.

## Cleaning agents

Pay attention to the information in the table to avoid damaging the various surfaces by incorrect cleaning agents.

Do not use

- harsh or abrasive cleaning agents
- metal or glass scrapers to clean the glass on the appliance door
- metal or glass scrapers to clean the door seal
- hard abrasive pads or cleaning sponges

Thoroughly rinse out new sponge cloths before use.

Area	Cleaning agent
Door panels	Glass cleaner: Clean with a window cloth or a microfibre cloth. Do not use a glass scraper.
Display	Wipe down using a microfibre cloth or a slightly damp cloth. Do not wipe with a wet cloth.

Area	Cleaning agent
Stainless steel	Hot soapy water: Clean using a dish cloth and then dry with a soft cloth. Remove flecks of limescale, grease, starch and albumin (e.g. egg white) immediately. Corrosion can form under these patches or splashes. Special stainless-steel cleaning agents are available from the after-sales service or from specialist retailers.
Aluminium	Clean with a mild window cleaning agent. Using a window cloth or a non-fluffing microfibre cloth, wipe over the surfaces lightly in a horizontal direction.
Cooking compartment	Hot soapy water: Clean with a dish cloth and dry with a soft cloth.  Do not use oven spray or other aggressive oven cleaners or abrasive materials. Scouring pads, rough sponges and pan cleaners are also unsuitable. These items scratch the surface.  Always dry the cooking compartment after cleaning it (see section entitled 'Drying programme').  For regular care of the stainless steel cooking compartment, use cooking compartment care products in accordance with the manufacturer's instructions (part number 00667027 from the after-sales service or from our online shop).  <b>Caution!</b> Undissolved detergent causes patches to appear when heating up. Remove all detergent and care product residues thoroughly with clean water before drying the cooking compartment.
Very dirty cooking compartment	The cleaning programme removes stubborn dirt (see section entitled 'Cleaning programme').
Glass ceramic grilling surface (only version with grill)	Clean the glass ceramic grilling surface in the cooking compartment regularly with glass ceramic cleaner (order number 00311499 from the after-sales service or from the online shop). Remove burned-on residues with a glass scraper.  <b>Caution!</b> Do not scratch the cooking compartment with the glass scraper.
Glass cover for the cooking compartment light	Hot soapy water: Clean with a dish cloth.

Area	Cleaning agent
Door seal Do not remove.	Hot soapy water: Clean with a dish cloth and do not scour. Do not use a metal or glass scraper for cleaning.
Core temperature probe	Wipe with a damp cloth. Do not clean in the dishwasher.
Cooking container, wire rack	Dishwasher or hot soapy water. Soak burned-on residues and clean with a brush.

### Microfibre cloth

The honeycomb microfibre cloth is particularly suitable for cleaning sensitive surfaces such as glass, glass ceramic, stainless steel or aluminium (part number 00460770 from our after-sales service or from our online shop). It removes liquid and greasy deposits in one go.

### Drain filter

You can clean the drain filter in the cooking compartment floor as necessary. If you use the appliance frequently to prepare fish or meat, we recommend cleaning it once a month.

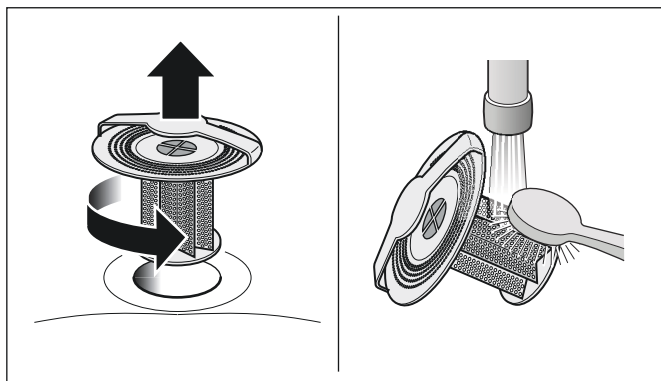

- 1 Turn the drain filter anti-clockwise and remove it.
- 2 Remove any food residues from the drain filter.
- 3 Rinse it out under running water. If it is very dirty, wash it in the dishwasher.
- 4 Insert the drain filter and turn it clockwise as far as it will go.

Never operate the combi-steam oven without the drain filter in place.

### Enamelled cooking compartment

The enamel in the cooking compartment will become lighter in colour with use. The change in colour does not affect its useful properties. Do not attempt to remove the discolouration by scouring with abrasive agents.

## Cleaning programme

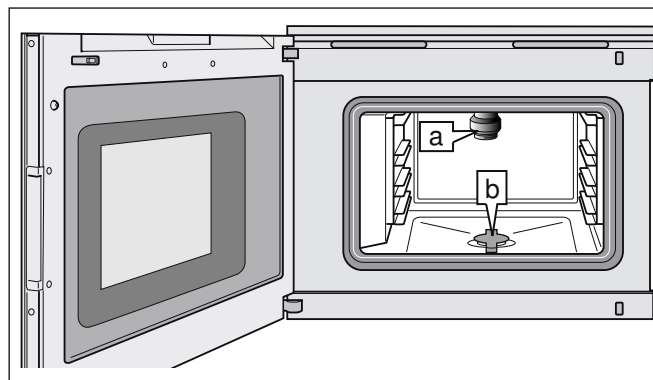

The cleaning programme removes stubborn dirt. A cleaning cartridge (a) is screwed into the top of the cooking compartment. The cooking compartment is cleaned, rinsed and dried fully automatically. The drain filter (b) must remain inserted in the cooking compartment floor while the cleaning programme is in progress.

The cleaning programme takes 3 hours 45 minutes from beginning to end.

With normal use, we recommend cleaning the appliance with the cleaning programme four times a year. Depending on how you use your appliance, more frequent cleaning may be necessary.

If there are a lot of food residues on the panels of the cooking compartment, do not allow them to burn on. Start the cleaning programme as soon as you have finished using the appliance.

You need special cleaning cartridges for the cleaning programme. These are available from the after-sales service or from our online shop (CL S10 040 set with four cleaning cartridges, part number 00311703).

The cleaning cartridges can only be used once and cannot be refilled. Do not use any other cleaning agents.

### Caution!

Damage to the cooking compartment: Use cleaning cartridges for the cleaning programme only. Never place cleaning cartridges in the cooking compartment when it is hot or heat them up in the cooking compartment.



### Notes

- The cleaning programme cannot be started until the appliance has cooled down to below 40 °C.
- Remove all accessories from the cooking compartment before you start the cleaning programme (wire rack, cookware, core temperature probe).
- Remove the worst of the food residues from the cooking compartment.
- The drain filter must remain inserted in the cooking compartment floor while the cleaning programme is in progress. If the drain filter is removed before the

cleaning programme is started, the cooking compartment will not be clean at the end of the programme.

- The appliance door will remain locked while the cleaning programme is in progress.
- Do not attempt to open the appliance door while the cleaning programme is in progress. Otherwise, water may leak out.
- Always allow the cleaning programme to run to the end. The cleaning programme cannot be cancelled.

### Starting the cleaning programme

- 1 Set the function selector to **S**.
- 2 The  symbol will be displayed. Press  to confirm.
- 3 The switch-off time at which the cleaning programme will end will be displayed. If required, you can alter the switch-off time using the rotary selector. Press  to confirm. The starting time and switch-off time will be altered but the cleaning time will remain the same.





- 4 Take all accessories out of the cooking compartment and remove the worst of the dirt. Press  to confirm.
- 5 Remove the locking cap from the cleaning cartridge.

#### Caution!

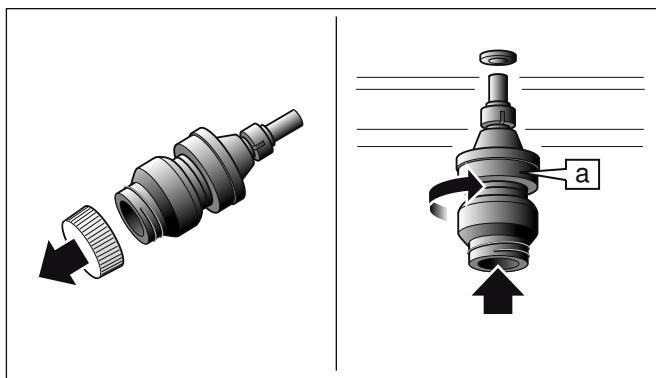
Do not remove the wax plug from the opening of the cleaning cartridge. Do not use any other cleaning agents. Do not use cartridges if they are damaged.



- 6 Screw the cleaning cartridge **(a)** fully into the socket in the top of the cooking compartment. Close the appliance door. Press  to confirm. A cleaning time of 3 hours 45 minutes will be displayed.

- 7 Press  to start. The cleaning time will count down on the display. The light in the cooking compartment will remain switched off. The appliance door will remain locked.

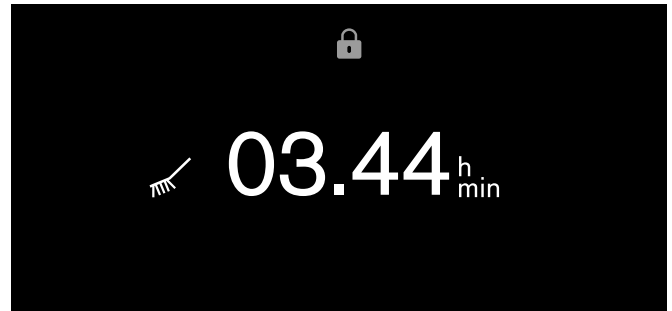

Once the cleaning programme has finished, an audible signal will sound. The appliance door will be unlocked. A message will appear on the display.

- 8 Remove the cleaning cartridge.

#### Caution!

Damage to the cooking compartment: Never heat the appliance while a cartridge is still in place.

- 9 Turn the drain filter on the cooking compartment floor anticlockwise and remove it. Remove any food residues from the drain filter. Rinse out under running water.

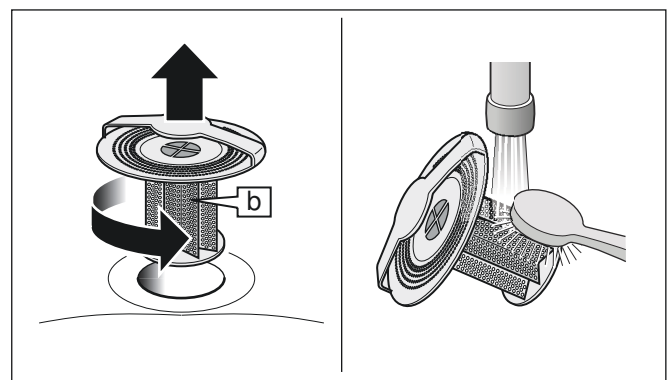

- 10 Insert the drain filter and turn it clockwise as far as it will go. Press  to confirm.

The cleaning programme has now ended. Allow the appliance to cool down. Then polish the cooking compartment and the glass with a soft cloth.

Dispose of the empty cleaning cartridge along with your household waste in accordance with the regional regulations.



## Causes of an unsatisfactory cleaning result

If the cooking compartment is still not clean once the cleaning programme has ended, use the table below to help you identify the causes. Then insert a new cleaning cartridge and start the cleaning programme again.



Possible cause	Solution
Locking cap on the cleaning cartridge	<p>The locking cap has not been removed from the cleaning cartridge.</p> <p>Once the cleaning programme has finished, remove the cartridge from the appliance. Do not reuse the cartridge. Dispose of the cartridge in accordance with the local regulations.</p> <p><b>⚠ Risk of injury!</b></p> <p>To prevent the cleaning agent from coming into contact with your skin or eyes, do not remove the locking cap from a spent cartridge.</p>
Wrong cartridge (descaling cartridge)	Use only genuine brand cleaning cartridges for the cleaning programme.
Drain filter not inserted	The drain filter must remain inserted in the cooking compartment floor while the cleaning programme is in progress.
Power cut	Following a power cut that lasts longer than 3 minutes, the cleaning programme will be ended with a short programme.
Stubborn burnt-on food residues	Run the cleaning programme again to remove stubborn food residues.

## Drying programme

With the drying program, you can dry the cooking compartment after cleaning or after steaming.

The drying program takes 20 minutes.

### Starting the drying program

- 1 Remove accessories from the cooking compartment. Wipe out the cooking compartment. Thoroughly remove residues of cleaner. Close the appliance door.
- 2 Set the function selector to **S**. Select the drying program with the rotary selector.
- 3 The  symbol is displayed. Touch  to confirm.
- 4 The drying time of 20 minutes appears. Touch  to start. The drying time elapses on the display. The lamp in the cooking compartment stays off.

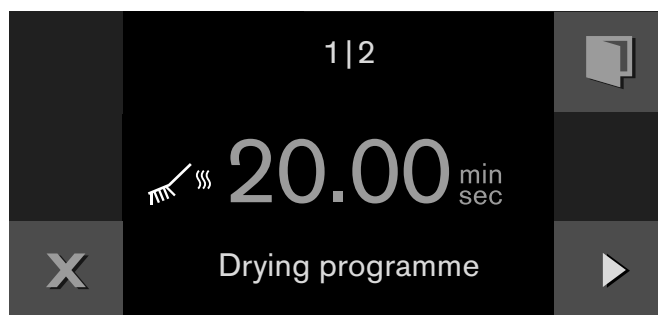

- 5 A signal sounds after 20 minutes. A message appears in the display. Touch  to confirm.

The drying programme has ended. Allow the appliance to cool down. Then polish the cooking compartment and the panel with a soft cloth.

## Descaling programme

Regular descaling keeps the cooking compartment in good condition. The cooking compartment is descaled, rinsed and dried fully automatically with the descaling programme.

Depending on the type of water and your use of the appliance, a message on the display reminds you to run the descaling programme. If necessary (e.g. if there are traces of limescale in the cooking compartment), you can run the descaling programme more frequently.

The descaling programme takes 2 hours 15 minutes from beginning to end.

You need special descaling cartridges for the descaling programme. These are available from the after-sales service or from our online shop (CL S20 040 set with four descaling cartridges, part number 00311768).



### Caution!

Damage to the cooking compartment: Use descaling cartridges for the descaling programme only. Never place descaling cartridges in the cooking compartment when it is hot or heat them up in the cooking compartment.

## Notes

- The descaling programme cannot be started until the appliance has cooled down to below 40 °C.
- Remove all accessories from the cooking compartment before you start the descaling programme (rack, cookware, core temperature probe).
- The drain filter must remain inserted in the cooking compartment floor while the descaling programme is in progress.
- The appliance door is locked while the descaling programme is in progress.
- Always allow the descaling programme to run to the end. The descaling programme cannot be cancelled.
- Even if you use the descaling and neutralising filter (special accessories GF 111 100), depending on the water type and your use of the appliance, descaling may be necessary. A message will appear on the display to remind you of this.

## Starting the descaling program

- 1 Set the function selector to **S**. Use the rotary selector to select the descaling programme.
- 2 The  symbol is displayed. Press  to confirm.
- 3 The switch-off time at which the descaling programme will end is displayed. If required, you can alter the switch-off time using the rotary selector. Press  to confirm.

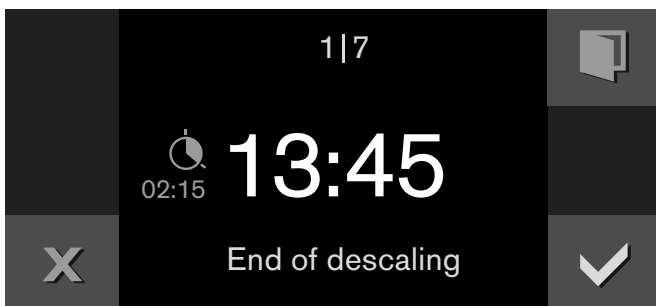



- 4 Remove all accessories from the cooking compartment. Press  to confirm.
- 5 Remove the locking cap from the descaling cartridge.

### Caution!

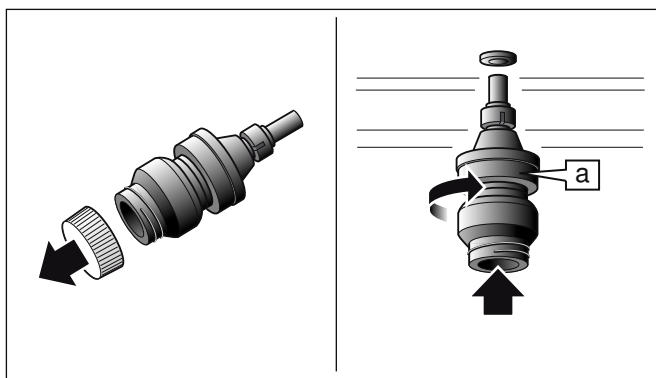

Do not remove the wax plug from the opening of the descaling cartridge. Do not use any other descaler.

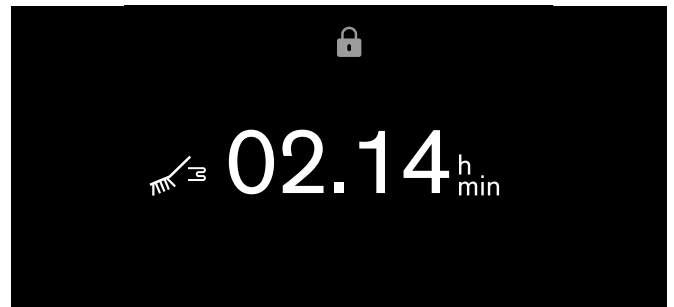

- 6 Screw the descaling cartridge (**a**) fully into the socket in the top of the cooking compartment. Close the appliance door. Press  to confirm. A descaling time of 2 hours 15 minutes is displayed.
- 7 Press  to start. The descaling time counts down on the display. The light in the cooking compartment remains switched off. The appliance door is locked.



Once the descaling programme has finished, an audible signal sounds. The appliance door is unlocked. A message appears on the display.

- 8 Remove the descaling cartridge. Confirm with .
- 9 Turn the drain filter on the cooking compartment floor anticlockwise and remove it. Remove any food residues from the drain filter. Rinse out under running water.
- 10 Insert the drain filter and turn it clockwise as far as it will go. Confirm with .

The descaling programme has finished. Then delete the descaling message on the display. Press .

Allow the appliance to cool down. Then polish the cooking compartment and the glass with a soft cloth.





Dispose of the empty descaling cartridge along with your household waste in accordance with the regional regulations.

## Trouble shooting

Malfunctions often have simple explanations. Please read the following notes before calling the after-sales service.

### Risk of electric shock!

Incorrect repairs are dangerous. Repairs may only be carried out and damaged power cables replaced by one of our trained after-sales technicians. If the appliance is defective, unplug the appliance from the mains or switch off the circuit breaker in the fuse box. Contact the after-sales service.

Disruption	Possible cause	Solution
Appliance not working, no display	Plug not inserted	Connect the appliance to the electricity mains
	Power failure	Check whether other kitchen appliances are working
	Fuse defective	Check in the fuse box whether the fuse for the appliance is in working order
	Operating error	Switch off the fuse for the appliance in the fuse box and switch it on again after about 60 seconds
Appliance cannot be started	Appliance door is not quite closed	Close appliance door
The appliance is not working and the display does not respond.  appears on the display	Childproof lock activated	Deactivate the childproof lock (see section entitled 'Childproof lock')
Appliance switches off on its own	Safety shut-off: the appliance has not been operated for longer than 12 hours	Confirm the message with  , switch off the appliance and set it again.
Appliance does not heat up,  appears in the display	Appliance is in demo mode	Deactivate the demo mode in the basic settings
The appliance cannot be started, a message is shown on the display	No water available in the appliance	Check the water connection
No steam visible in the oven	Steam above 100°C is invisible	This is normal
The grilling surface only lights up around the sides, not in the middle	Only the side of the grilling surface is heated to allow for better heat distribution	This is normal
The "steam removal"  symbol does not appear on the display	The steam removal function is only available if the oven temperature is below 130°C	This is normal
A lot of steam escapes at the top of the door	Appliance is calibrating the boiling point or is preheating or the heating mode has been changed	This is normal
	The appliance has not yet been calibrated	Calibrate the appliance
A lot of steam escapes at the side of the door	Door seal soiled or loose	Clean the door seal and insert it in the groove
Humming noise when switching on	The drain pump starts to operate	This is normal
	Appliance has been switched off for several days	This is normal: automatic rinsing when being switched on again
There is a "pop" noise during cooking	Cold/warm effect with frozen food, caused by the steam	This is normal
The appliance is not producing steam properly	Limescale has formed in the appliance	Start the descaling programme
The cooking compartment is wet after operation	This is normal depending on the operating mode set by the user	After operation, dry the cooking compartment using the drying programme

---

Error message "Exxx"

If an error message is displayed, turn the function selector to **0**; if the display goes out, there was a non-recurring problem. If the error occurs repeatedly or the display remains on, please contact the after-sales service and inform them of the error code.

---

## Power cut

Your appliance can bridge a power cut of a few seconds. Operation continues.

If the power cut was for a longer period and the appliance was in operation, a message appears in the display. Operation is interrupted.

Set the function selector to **0**, then the appliance can be operated again as usual.

## Demo mode

The  symbol appears on the display when the appliance is in demo mode. The appliance will not heat up.

Briefly disconnect the appliance from the mains (switch off the household fuse or the circuit breaker in the fuse box). Then deactivate demo mode in the basic settings within 3 minutes (see section entitled 'Basic settings').

## Replacing the oven light

For technical reasons the lamp cover cannot be removed. Lamp must only be replaced by Gaggenau after-sales service.

### Caution!

Do not remove the lamp cover. This will damage the sealing.

If the lamp cover in the oven is damaged, it must be replaced. You can obtain covers from the after-sales service. Please supply your appliance's E number and FD number.

---

## After-sales service

---

In the event of repairs please contact our after-sales service. We are committed to find the best solution also in order to avoid an unnecessary call-out.

Please quote the E number (product number) and the FD number (production number) of your appliance when contacting the after-sales service. The rating plate bearing these numbers can be found on the front side when you open the appliance door.

For future reference you can note the data of your appliance and the telephone number of our after-sales service below.

---

E-Nr.	FD-Nr.
-------	--------

---

---

**After-sales service** 

---

Please note that calling out an after-sales service technician is not free of charge, even within the warranty period, should the problem result from an operating error.

Please find the contact data of all countries in the enclosed customer service list.

### To book an engineer visit and product advice

**GB** 0344 892 8988  
Calls charged at local or mobile rate.

**IE** 01450 2655  
0.03 € per minute at peak.  
Off peak 0.0088 € per minute.

**AU** 1300 368 339

**NZ** 09 477 0492

Trust the expertise of the manufacturer, and rest assured that the repair will be carried out by trained service technicians using original spare parts for your domestic appliance.

## Settings table and tips

### Notes

- The cooking times specified are intended as a guide. The actual cooking time depends on the quality and temperature of the food before cooking, and the weight and thickness of the food to be cooked.
- Always preheat the appliance. This will provide the best cooking results.  
The cooking times specified refer to a preheated appliance. Add approximately 5 minutes to these times if you are placing food into the appliance without preheating it.
- The figures given refer to average quantities of food for four people. If you wish to prepare a larger quantity of food, you should allow for a longer cooking time.
- Use the cookware specified. If you use other cookware, the cooking times may be longer or shorter.
- If you have not made a particular dish before, use the shortest time specified to start with. If necessary, you can always cook the food for longer.
- Open the cooking compartment door of the preheated oven for a short time only and do not take too long to place your food inside the appliance.
- When using only one cooking container, place it in the appliance at the second level from the bottom.
- When steaming, defrosting, dough proving and reheating, you can use up to three rack levels at a time (rack levels 2, 3 and 4 from the bottom). This will not cause any transfer of flavours. This allows fish, vegetables and desserts to be prepared at the same time. However, the specified cooking times may need to be extended for large quantities of food.
- Only one level can be used for baking; the second level from the bottom is designated for this.
- Do not allow the food to come into contact with the cooking compartment, grease filter or back panel of the oven.
- The combi-steam oven must be able to shut properly. To ensure that this is possible, keep the seal surfaces clean at all times.
- Do not place too many items close together on wire racks or containers. This is to allow optimal steam circulation.
- If you wish to prepare food using steam and the appliance has been heated to over 100°C (for example because it has just been used for baking), allow the appliance to cool down before steaming your food. Otherwise, the high temperature will cause your food to dry out.

## Vegetables

- Vegetables are prepared more gently in steam than in boiling water. Their taste, color and consistency are preserved better. Vitamins and ingredients that are soluble in water are not washed out. As the steam oven operates without pressure at only 100°C, food is prepared considerably more gently than in a pressure cooker, for example.
- All data refers to 1 kg of cleaned vegetables.
- Use the perforated cooking container to steam vegetables, sliding it into the second level from below. Insert the unperforated cooking container under it. You can collect the vegetable juice and use it as the base for a sauce or a vegetable broth.
- Blanch vegetables for 8 - 10 minutes in the preheated appliance. If vegetables or fruits are not served straight away, place them in ice water to prevent simmering in the residual heat.

Food	Cooking container	Temperature in °C	Humidity in %	Cooking time in min.	Comments
Artichokes, large	Perforated	100	100	30 - 40	
Artichokes, small	Perforated	100	100	20 - 25	
Cauliflower, whole	Perforated	100	100	25 - 30	
Cauliflower, in florets	Perforated	100	100	15 - 25	
Beans, green	Perforated	100	100	25 - 30	
Broccoli, in florets	Perforated	100	100	15 - 20	Recipe tip: Serve with almonds that have been roasted in butter.
Fennel, sliced	Perforated	100	100	15 - 20	

Food	Cooking container	Temperature in °C	Humidity in %	Cooking time in min.	Comments
Vegetable terrine	Perforated/ wire rack	100	100	50 - 60	In a terrine mould Use the core temperature probe to check the exact cooking temperature (see section entitled 'Core temperature sensor').
Carrots, in 0.5 cm slices	Perforated	100	100	15 - 20	
Potatoes, peeled and quartered	Perforated	100	100	25 - 35	
Kohlrabi, sliced	Perforated	100	100	20 - 30	
Leeks, sliced	Perforated	100	100	10 - 15	
Peppers, stuffed	solid	180 - 200	80 / 100	20 - 25	If stuffing with meat, sear the meat beforehand.
Unpeeled boiled potatoes (approx. 50 g/piece)	Perforated	100	100	30 - 35	
Unpeeled boiled potatoes (approx. 100 g/piece)	Perforated	100	100	45 - 50	
Brussels sprouts	Perforated	100	100	20 - 25	
Asparagus, green	Perforated	100	100	12 - 15	
Asparagus, white	Perforated	100	100	20 - 30	
Spinach	Perforated	100	100	4 - 6	Then sweat in a pan with onions and garlic.
Peeling tomatoes	Perforated	100	100	3 - 4	Cut the tomatoes, and rinse with ice-cold water after steaming.
Mangetout	Perforated	100	100	5 - 10	

## Fish

- Steaming is a cooking method that does not use any fat and does not allow fish to dry out.
- For food hygiene reasons, fish should have a core temperature of at least 62-65 °C after cooking. This is also the ideal cooking temperature.
- Do not season the fish with salt until it is fully cooked. This ensures that the natural flavour is retained and that less water is drawn out of the fish.
- When using the perforated cookware, you can grease the cookware if the fish sticks too much.
- Slide the unperforated cooking insert into the first level from below to avoid getting fish stock on the cooking compartment surfaces.
- For fillets with skin, place the fish on the cooking insert or wire rack with the skin side up – this helps to retain its texture and flavour.

Food	Cooking container	Temperature in °C	Humidity in %	Cooking time in min.	Comments
Sea bream, whole (500 g/piece)	solid	90 - 100	100	18 - 20	Can be cooked in the swimming position if placed on half a potato.
Fish dumplings (20 - 40 g/piece)	solid	90 - 100	100	4 - 8	Line the unperforated cookware with grease-proof paper.
Lobster, cooked, shelled, reheating	Perforated	70 - 80	100	10 - 12	
Carp, rare, whole (1.5 kg)	solid	90 - 100	100	35 - 45	In stock
Salmon fillet (150 g/piece)	Perforated	90 - 100	100	10 - 12	
Salmon, whole (2.5 kg)	Perforated	100	100	65 - 75	
Blue mussels (1.5 kg)	Perforated	100	100	6 - 8	Blue mussels are cooked once the shell has opened up.
Pollock, whole (800 g)	Perforated	90 - 100	100	18 - 20	

Food	Cooking container	Temperature in °C	Humidity in %	Cooking time in min.	Comments
Monkfish fillet (300 g/piece)	Glass dish/ wire rack	180 - 200	100	8 - 10	In juices
Sea bass, whole (400 g/piece)	Perforated	90 - 100	100	12 - 18	

## Fish – low-temperature steaming

- If you steam the fish at between 70 and 90 °C, it is less likely to be overcooked or to fall apart. This is a particular advantage for delicate fish.
- The values given for the different types of fish refer to fillets.
- Slide the unperforated cooking insert into the first level from below to avoid getting fish stock on the cooking compartment surfaces.
- Serve on pre-warmed plates.

Food	Cooking container	Temperature in °C	Humidity in %	Cooking time in min.	Comments
Oysters (x 10)	solid	80 - 90	100	2 - 5	In stock
Tilapia (150 g/piece)	Perforated	80 - 90	100	10 - 12	
Sea bream (200 g/piece)	Perforated	80 - 90	100	12 - 15	
Fish fillet (200 - 300 g/piece)	Perforated	80 - 90	100	12 - 15	
Fish terrine	Wire rack	70 - 80	100	50 - 90	In a terrine mould Use the core temperature probe to check the exact cooking temperature (see section entitled 'Core temperature sensor').
Trout, whole (250 g/piece)	Perforated	80 - 90	100	12 - 15	
Halibut (300 g/piece)	Perforated	80 - 90	100	12 - 15	
Scallops (15 - 30 g/piece)	solid	80 - 90	100	4 - 8	The more the scallops weigh, the longer the chosen cooking time should be.
Cod (250 g/piece)	Perforated	80 - 90	100	10 - 12	
Red snapper (200 g/piece)	Perforated	80 - 90	100	12 - 15	
Ocean perch (120 g/piece)	Perforated	80 - 90	100	10 - 12	
Monkfish (200 g/piece)	Perforated	80 - 90	100	10 - 15	
Sole rolls, stuffed (150 g/piece)	Perforated	80 - 90	100	12 - 15	
Turbot (300 g/piece)	Perforated	80 - 90	100	12 - 15	
Sea bass (150 g/piece)	Perforated	80 - 90	100	10 - 12	
Pike-perch (250 g/piece)	Perforated	80 - 90	100	12 - 15	









## Meat – cooking at higher temperatures

- Combining steam and hot air is the best way of cooking many types of fish. In this operating mode, the cooking compartment is hermetically sealed and the moisture counteracts the drying effects of the hot air, which is used in conventional cooking. The optimal conditions can be achieved for any type of food thanks to the variable humidity control system.
- The cooking times listed are intended as a guide only, and depend heavily on the temperature of the meat at the start of cooking and on how long the meat was seared for. Use the core temperature probe so that you can monitor the core temperature more easily. Information and instructions, as well as optimal target temperatures, can be found in the section entitled 'Core temperature probe'.
- Take the meat out of the refrigerator 1 hour before you begin preparing it.
- When using the perforated cooking insert or the wire rack, slide in an item of cookware with an unperforated base beneath it. Pour a little water into the unperforated cooking insert to prevent the meat from burning on. You can also add vegetables, wine, spices and herbs to it to make a tasty base for a sauce.
- If you want the meat to be rare or medium rare, open the door when the temperature reaches 5 °C below the required core temperature and wait until the target temperature is reached. This prevents overcooking and allows the meat the necessary time to rest.
- Time to rest: Allow the meat to rest for 5 minutes on a wire rack after cooking. This gives the meat a chance to "relax". The meat juices begin to circulate less, and when the meat is cut, less juice is lost.

Food	Cooking container	Temperature in °C	Humidity in %	Cooking time in min.	Comments
Entrecôte, seared, medium rare (350 g/piece)	solid	170 - 180	30	10 - 20	
Fillet, seared, medium rare, in puff pastry (600 g)	solid	180 - 200	80 / 100	30 - 45	Line the cookware with greaseproof paper.
Saddle of veal, seared, medium rare (1 kg)	solid	160 - 180	30 / 60	20 - 30	If you have added liquid to the unperforated cookware, 30% humidity is sufficient.
Smoked pork, cooked, sliced	solid	100	100	15 - 20	
Roast pork with crackling (joint of pork with rind), well done (1.5 kg)	Wire rack	1) 120 2) 160 3) 230	100 80 0	30 30 - 40 20 - 40	With a knife, crosshatch the rind before cooking. Use the core temperature probe: In the second stage of cooking, cook the food to a core temperature of up to approximately 60 °C, and in the third stage of cooking, cook it up to a core temperature of 75 - 80 °C.
Saddle of lamb, seared, medium rare (150 g/piece)	solid	160 - 170	0 / 30	12 - 15	
Leg of lamb, seared, medium rare (1.5 kg)	solid	170 - 180	30 / 60	60 - 80	
Saddle of venison, seared, medium rare (500 g/piece)	solid	160 - 170	0 / 30	12 - 18	
Joint of beef, well done (1.5 kg)	Wire rack	1) 210 - 230 2) 140 - 160	100 30 / 60	15 - 20 60 - 90	If you have added liquid to the unperforated cookware, 30% humidity is sufficient.
Sirloin, seared, medium rare (1 kg)	solid	170 - 180	30	50 - 60	
Pork roast (neck or shoulder), well done (1 - 1.5 kg)	Wire rack	1) 200 - 220 2) 160 - 180	100 60	15 40 - 60	If you have added liquid to the unperforated cookware, 30% humidity is sufficient.
Sausages, boiled, heating	solid	85 - 90	100	10 - 20	E.g. Bologna sausages, Bavarian veal sausages

## Meat/poultry – low-temperature cooking

- Meat seared at a high temperature develops as it cooks for an extended period at a low temperature. This gives the meat an even, delicate pink colour throughout (other than a very thin edge) and makes it extraordinarily succulent. You do not need to turn the meat during cooking or pour any liquid over it.
- The cooking times listed are intended as a guide only, and depend heavily on the temperature of the meat at the start of cooking and on how long the meat was seared for. Use the core temperature probe so that you can monitor the core temperature more easily. Information and instructions, as well as optimal target temperatures, can be found in the section entitled 'Core temperature probe'.
- Take the meat out of the refrigerator 1 hour before you begin preparing it.
- For food hygiene reasons, sear the meat briefly on all sides at a high temperature in the frying pan before cooking it. This gives the meat a crust, which prevents the meat juices from escaping and produces the kind of flavour characteristic of fried meat.
- Season with care: Because the meat develops as it cooks slowly, all of the flavours become more intense.
- When game and horse meat is cooked at low temperatures, its flavour becomes stronger than when prepared the conventional way.
- Use "Low-temperature cooking" mode . In this mode, any moisture escaping from the food remains in the cooking compartment and prevents the food from drying out.
- Please note that the core temperature of the food cannot be higher than the temperature inside the cooking compartment. As a rule of thumb, the temperature that is set in the cooking compartment should be 10 - 15 °C above the required core temperature.
- Towards the end of the cooking time, you can reduce the temperature to 60 °C. This will allow you to extend the cooking time (e.g. if your guests are going to be late). If you wish to pause cooking, the temperature in the cooking compartment must be no higher than the required core temperature. This means that large items can remain in the cooking compartment for 1 - 1.5 hours and small items can remain there for 30 - 45 minutes.
- Serve on pre-warmed plates.

Food	Cooking container	Temperature in °C	Type of heating	Cooking time in min.	Comments
Duck breast, medium rare (350 g/piece)	solid	70 - 80		40 - 60	After cooking, you can crisp up the skin side quickly in the frying pan
Entrecôte, medium rare (350 g/piece)	solid	70 - 80		40 - 70	
Leg of lamb, boned, tied, medium rare (1.5 kg)	solid	70 - 80		180 - 240	Turn in garlic and herbs before cooking in oil.
Beef steaks, medium rare (175 g/piece)	solid	70 - 80		30 - 60	
Sirloin, medium rare (1 - 1.5 kg)	solid	70 - 80		150 - 210	Slice and serve with béchamel sauce
Pork medallions, well done (70 g each)	solid	80		50 - 70	

## Poultry

- The moisture present when the appliance is operating in 'Combination' mode prevents food from drying out, which is important for poultry in particular. At the same time, the high temperatures make the surface brown and crispy. The hot steam is able to transfer twice as much heat as conventional hot air, and reaches all parts of the food. This allows a chicken to be evenly browned and crispy all round, while the breast meat remains tender and succulent.
- The cooking times listed are intended as a guide only, and depend heavily on the temperature of the meat at the start of cooking. Use the core temperature probe so that you can monitor the core temperature more easily. Insert this between the belly and the thigh, rather than in the middle (cavity) of the bird. Further information and instructions, as well as optimal target temperatures, can be found in the section entitled 'Core temperature probe'.
- To make the skin crispier, season poultry mainly with spices and herbs, and use little or no oil.

Food	Cooking container	Temperature in °C	Humidity in %	Cooking time in min.	Comments
Duck, whole (3 kg)	solid	1) 150 - 160 2) 220	60 0	80 - 90 20 - 30	Cook with the breast side facing down. Turn the duck once half the cooking time has elapsed. This prevents the delicate breast meat from drying out as much.
Duck breast, seared, medium rare (350 g/piece)	solid	160	0	25 - 30	
Chicken, whole (1.5 kg)	Wire rack	1) 170 - 180 2) 190	60 0	35 - 45 15 - 20	Tie the thighs together and cook the bird with the breast side facing up.
Chicken breast, stuffed, steamed (200 g/piece)	Perforated	100	100	10 - 15	Recipe tip: Stuff with spinach and sheep's cheese.
Turkey breast fillet, steamed (300 g/piece)	Perforated	100	100	12 - 15	
Poussin, quail, steamed (150 - 200 g/piece)	Perforated	100	100	15 - 20	
Poussin, quail (150 - 200 g/piece)	solid	180 - 200	60 / 80	15 - 20	Recipe tip: Brush with oil and herbes de provence.
Pigeon, steamed (300 g/piece)	Perforated	100	100	20 - 30	
Pigeon (300 g/piece)	solid	180 - 200	60 / 80	25 - 30	

## Sous-vide cooking

Sous-vide cooking is a method of cooking under a vacuum at low temperatures between 50 - 95 °C and in 100% steam.

Sous-vide cooking is a gentle, low-fat method of preparing meat, fish, vegetables and desserts. A vacuum-packing machine is used to heat-seal the food in a special air-tight, heat-resistant cooking bag.

The protective envelope retains the nutrients and flavours. The low temperatures and the direct transfer of heat allow precisely controlled cooking in order to achieve the desired cooking results. It is almost impossible to overcook the food.

### Portions

Use the portion sizes listed in the cooking table. For relatively large quantities and items, the cooking time must be adjusted accordingly.

The portions given for fish, meat and poultry correspond to a single serving. A portion size sufficient for four people has been selected for vegetables and desserts.

### Rack levels

You can cook on up to two levels. Place the cooking containers on levels 1 and 3 to achieve the best cooking results. When cooking on just one level, use level 2.

### Hygiene

#### Health risk!

Sous-vide cooking is a method of cooking at low temperatures. As a result, it is important that you always follow the application and hygiene instructions below:

- Use only fresh, good-quality food.
- Wash and disinfect your hands. Use disposable gloves or cooking/grill tongs.
- Take extra care when preparing critical food, such as poultry, eggs and fish.
- Always thoroughly rinse and/or peel fruit and vegetables.
- Always keep work surfaces and chopping boards clean. Use different chopping boards for different types of food.
- Maintain the cold chain. Make sure that you only interrupt it briefly to prepare the food, and then return the food in its vacuum-sealed bag to the refrigerator for storage before you cook it.
- Food is suitable for immediate consumption only. Once the food is cooked, consume it immediately. Do not store it after cooking – not even in the refrigerator. It is not suitable for reheating.

### Vacuum-pack bags

When using the sous-vide cooking method, only use heat-resistant vacuum-pack bags designed for this purpose.

Do not cook the food in the bag you bought it in (e.g. portions of fish). These bags are not suitable for sous-vide cooking.

### Vacuum sealing

Use a chamber vacuum-packing machine that can create a vacuum of 99% to vacuum-seal the food. This is the only way to achieve even heat transfer and therefore a perfect cooking result.

Before cooking the food, check whether the vacuum in the bag is intact. Make sure that:

- There is no/hardly any air in the vacuum-pack bag.
- The seam is perfectly sealed.
- There are no holes in the vacuum-pack bag – do not use the core temperature probe.
- Pieces of meat and fish that have been vacuum-sealed together are not pressed directly against one another.
- As far as possible, you avoid piling up vegetables and desserts when vacuum-sealing them.

If in doubt, place the food into a new bag and vacuum-seal it again.

Food should be vacuum-sealed at most one day before it is cooked. This is the only way to prevent the escape of gases from the food (e.g. from vegetables) which inhibit the transfer of heat, or to prevent the texture of the food from changing, and thus altering how it cooks.

### Quality of the food

The quality of the cooking result is 100% influenced by the quality of the ingredients you use. Use only fresh, top-quality food. This is the only way to guarantee a consistent cooking result that delivers impeccable flavour.

### Preparation

Sous-vide cooking prevents flavours from escaping, intensifying the food's natural flavour. Please note that the usual quantities of seasoning and condiments, such as herbs, spices and garlic, will have a much greater effect on the flavour. Start off by halving the quantities you usually use.

If the ingredients are of high quality, it is often sufficient to enclose them in the bag with just a small knob of butter and a little salt and pepper. Generally, the fact that the food's natural flavours intensify during cooking is sufficient on its own to produce a flavourful cooking result.

Do not place the vacuum-sealed food items on top of one another or too close together in the cooking containers. In order to ensure that the heat is distributed evenly, the food items should not be touching. If you have more than one vacuum-pack bag, cook on two levels.

Remove the vacuum-pack bags with care after cooking as hot water accumulates on the bags. Place the unperforated cooking container onto the rack and underneath the perforated cooking container containing the hot food.

Dry the outside of the bag, place it into a clean, unperforated cooking container and cut it open with scissors. Place all of the food, along with its juices, into the cooking container.

**The food can be finished off as follows once the sous-vide cooking stage is complete:**















**Meat:** Flash fry at a very high temperature for a few seconds only on each side. This gives it a nice crust and the flavours you would expect from frying, without overcooking it. You can achieve a particularly good result using a teppan yaki or under the grill. Important: Dab the meat with a tea towel before placing it into hot oil, in order to avoid fat spitting out of the pan.

















**Vegetables:** Flash fry in a frying pan or on a teppan yaki to give them the flavours you would expect from frying. When frying vegetables like this, it is easy to season them or mix them with other ingredients without them cooling down.

**Fish:** Season and coat with hot butter. Since many types of fish fall apart easily after cooking using the sous-vide method, if you wish to flash fry it, this should be done before the sous-vide cooking stage.

Fry the food for longer if has not been sufficiently well cooked during the sous-vide cooking stage.











Serve the food on pre-heated plates and, if possible, with a hot sauce or butter as sous-vide cooking takes place at relatively low temperatures.

Food	Cooking container	Temperature in °C	Type of heating	Cooking time in min.	Comments
<b>Meat</b>					
Entrecôte, rare (180 g/piece)	Perforated	58		100	Once the meat is cooked, sear it on a teppan yaki or grill it at a high temperature on both sides. This gives the meat a nice crust and the flavours you would expect from frying, without overcooking it.
Entrecôte, medium rare (180 g/piece)	Perforated	63		90	
Entrecôte, well done (180 g)	Perforated	70		85	
Veal topside steaks (160 g/piece)	Perforated	60		80	
Beef steaks, rare (180 g/piece)	Perforated	58		60	
Beef steaks, medium rare (180 g/piece)	Perforated	63		50	
Beef steaks, well done (180 g/piece)	Perforated	70		45	
Pork medallions (80 g/piece)	Perforated	63		75	
<b>Poultry</b>					
Duck breast (350 g/piece)	Perforated	58		70	Once the breast is cooked, fry the skin side in a hot frying pan until it is crispy.
Foie gras (300 g/1 round)	Perforated	80		30	Recipe tip: Prepare the goose liver and mix it with other ingredients. Roll it in foil and prick it several times. Vacuum-seal the round and leave it to chill for several hours in the refrigerator before cooking it using the sous-vide method.
Chicken breast (250 g/piece)	Perforated	65		60	
<b>Fish and seafood</b>					
Prawns (125 g)	Perforated	60		30	Recipe tip: Vacuum-seal along with some olive oil, salt and garlic.
Scallops (20 - 50 g/piece)	Perforated	60		6 - 10	The more the scallops weigh, the longer the chosen cooking time should be.
Cod (140 g/piece)	Perforated	59		25	
Salmon fillet (140 g/piece)	Perforated	58		30	If you wish, you can flash fry the salmon fillet in a hot frying pan once it is cooked.

Food	Cooking container	Temperature in °C	Type of heating	Cooking time in min.	Comments
Pike-perch (140 g/piece)	Perforated	60		20	
<b>Vegetables</b>					
Mushrooms, quartered (500 g)	Perforated	85		20	Recipe tip: Vacuum-seal along with some butter, rosemary, garlic and salt.
Chicory, halved (4 - 6 pieces)	Perforated	85		40	Recipe tip: Cut the chicory in half. Vacuum-seal along with some orange juice, sugar, salt, butter and thyme.
Green asparagus, whole (600 g)	Perforated	85		15 - 20	Recipe tip: Blanch before vacuum-sealing to retain the colour. Vacuum-seal along with some butter, salt and pepper.
Carrots, in 0.5 cm slices (600 g)	Perforated	95		35 - 40	Recipe tip: Vacuum-seal along with some orange juice, curry and butter.
Potatoes, peeled, in 2 x 2 cm cubes (800 g)	Perforated	95		40	Recipe tip: Vacuum-seal along with some butter and salt. Can easily be used for making dishes such as salad.
Potatoes, skin on, whole or halved (800 g)	Perforated	95		50	Recipe tip: Vacuum-seal along with some butter and salt. Wash thoroughly beforehand.
Cherry tomatoes, whole or halved (500 g)	Perforated	85		15	Recipe tip: Vacuum-seal along with some olive oil, salt and sugar. Mix together red and yellow cherry tomatoes.
Pumpkin, in 2 x 2 cm cubes (600 g)	Perforated	90		20 - 25	The cooking time may vary depending on the type of pumpkin.
Courgettes, in 1 cm slices (600 g)	Perforated	85		30	Recipe tip: Vacuum-seal along with some olive oil, salt and thyme.
Mangetout, whole (500 g)	Perforated	85		5 - 10	Recipe tip: Vacuum-seal along with some butter and salt.
<b>Dessert</b>					
Pineapple in 1.5 cm slices (400 g)	Perforated	85		70	Recipe tip: Vacuum-seal along with some butter, honey and vanilla.
Apple, peeled, in 0.5 cm slices (2 - 4 pieces)	Perforated	85		10 - 15	Recipe tip: Vacuum-seal along with some caramel sauce.
Bananas, whole (2 - 4 pieces)	Perforated	65		15 - 20	Recipe tip: Vacuum-seal along with some butter, honey and a vanilla pod.
Pear, peeled, sliced (2 - 4 pieces)	Perforated	85		30	Recipe tip: Add honey or sugar to sweeten.
Kumquats, halved (12 - 16 pieces)	Perforated	85		75	Recipe tip: Vacuum-seal along with some butter, a vanilla pod, honey and apricot jam. Rinse under warm water, cut in half and deseed.
Vanilla sauce (0.5 l)	Perforated	82		18 - 20	Recipe tip: 0.5 l milk, 1 egg, 3 egg yolks, 80 g sugar, 1 vanilla pod.

## Grilling

- If required, you can increase the degree of browning on the food using the various grill functions.
- Use slide-in levels 1 - 3 only for operating modes that use the full surface grill. Always make sure the appliance door is closed when you are grilling food.
- Use the different slide-in levels to achieve the required level of browning. If you place the food on the first level from the bottom, it will be lightly browned; if you place it on the third level from the bottom, it will be dark brown in colour.
- If your food is not brown enough after grilling, you can place it on the second level and finish it off using the 'Full surface grill' mode.
- Do not preheat the appliance for more than 5 minutes when using the 'Full surface grill' or 'Full surface grill + circulated air' mode as it will start grilling after 5 minutes.
- Do not use the core temperature probe when using the 'Full surface grill', 'Full surface grill + circulated air' or 'Full surface grill + humidity' mode.

Food	Cookware, level	Temperature in °C	Type of heating	Cooking time in min.	Comments
Meringue topping (on cakes/desserts)	Wire rack 2	230		3 - 5	
Toast with topping	Wire rack + unperforated 2 / 3	200		10 - 12	
Trout (whole)	Wire rack + unperforated 3	230		10 - 12 on each side	Recipe tip: Stuff with sliced lemon and parsley.
Grilled vegetables (700 g)	solid 2	230		20 - 25	E.g. courgettes, aubergines
Vegetable bake	solid 2	180		35 - 40	E.g. with broccoli and cauliflower
Vegetable kebabs	Wire rack + unperforated 3	230	 / 	12 - 14 on each side	The cooking time depends on the types of vegetable.
Chicken thighs (350 g/piece)	Wire rack + unperforated 2 / 3	180 - 200		35 - 40	
Potato gratin (1 kg potatoes)	solid 2	180		35 - 40	
Toast (in accordance with EN60350-1)	Wire rack 2	230		4 - 5	Preheat the appliance for 5 minutes.
Topped, grilled courgettes, stuffed, halved lengthways	solid 2	180		20 - 25	

## Side dishes

Also follow the instructions on the packaging.

Food	Cooking container	Temperature in °C	Humidity in %	Cooking time in min.	Comments
Basmati rice (250 g + 500 ml water)	solid	100	100	15 - 20	
Couscous (250 g + 250 ml water)	solid	100	100	5 - 10	
Dumplings (90 g/piece)	Perforated/ unperforated	95 - 100	100	20 - 25	
Long-grain rice (250 g + 500 ml water)	solid	100	100	20 - 25	
Brown rice (250 g + 375 ml water)	solid	100	100	25 - 35	
Lentils (250 g + 500 ml water)	solid	100	100	25 - 35	
Haricot beans, pre-soaked (250 g + 1 l water)	solid	100	100	55 - 65	

## Desserts





Food	Cooking container	Temperature in °C	Humidity in %	Cooking time in min.	Comments
Crème brûlée (130 g each)	solid	90	100	40 - 45	In ramekins, cover with heat-resistant cling film.
Yeast dumplings (100 g/piece)	solid	100	100	20 - 30	Allow yeast dumplings to rise for 30 minutes before steaming (see section entitled 'Dough proving').
Crème caramel (130 g each)	Perforated	90 - 95	100	30 - 35	In ramekins, cover with heat-resistant cling film.
Compote	solid	100	100	15 - 25	E.g. apples, pears, rhubarb Recipe tip: Add sugar, vanilla sugar, cinnamon or lemon juice.
Rice pudding (250 g rice + 625 ml milk)	solid	100	100	35 - 45	Recipe tip: Add fruit, sugar or cinnamon.
Sweet bake	solid	180 - 200	0 / 60	20 - 40	E.g. semolina, quark or pre-cooked rice pudding



## Miscellaneous

Food	Cooking container	Temperature in °C	Humidity in %	Cooking time in min.	Comments
Sterilising (e.g. baby bottles, jam jars)	Wire rack	100	100	20 - 25	
Drying fruit or vegetables	Perforated	80 - 100	0	180 - 300	E.g. thinly sliced tomatoes, mushrooms, courgettes, apples, pears, etc.
Eggs, medium (x 5)	Perforated	100	100	8 - 15	
Royale (500 g)	Glass dish, wire rack	90	80 - 100	25 - 30	Cover with heat-resistant cling film.
Semolina dumplings	solid	90 - 95	100	8 - 10	
Lasagne	solid	170 - 190	0 /60	35 - 60	
Soufflé	Ramekins, wire rack	180 - 200	60	12 - 20	
Melting chocolate	Heat-resistant bowl, wire rack	100	100	5 - 8	Cover with heat-resistant cling film.

## Baking

- Using the steam oven, you can prepare your baked items with the optimum humidity:
  -  | Hot air + 0% humidity: moisture can escape in the case of fruit cakes and quiche. This mode corresponds to hot air in the conventional oven.
  -  | Hot air + 30% humidity: mixed cake does not dry out. The intrinsic humidity in a food cannot escape from the oven interior.
  -  | Hot air + 60 - 100% humidity: puff pastry and yeast-risen pastries become looser on the inside and crispy on the outside with a gloss.
- You can only bake on one level in the steam oven. Insert the unperforated cooking container into the second level. When using a high baking tin, place it on the wire rack, which you then insert in the first level.
- Misting brings additional steam to the food during baking with Hot air + 0% humidity or with Hot air + 30% humidity when touching the  symbol. Use the misting function for example when baking bread at the beginning of the baking time. The bread will increase in volume and will get a crispy crust.

Food	Cooking container	Temperature in °C	Humidity in %	Cooking time in min.	Comments
Apple pie (in accordance with EN 60350-1)	20 cm springform cake tin, wire rack	160	0	110	Preheat
Bagels	solid	190 - 210	80 - 100	20 - 25	
Baguette, pre-baked	Wire rack	190 - 200	0 - 80	10 - 15	
Sponge base, thick (6 eggs)	Springform cake tin	160 - 170	0	30 - 35	
Sponge base, thin (2 eggs)	solid	190 - 210	0 - 30	8 - 10	E.g. for Swiss rolls
Danish pastries	solid	190 - 210	80 - 100	10 - 18	E.g. with poppy seeds, marzipan, or savoury with ham, cheese
Brioche, bread rolls	solid	160	0	8 - 12	

Food	Cooking container	Temperature in °C	Humidity in %	Cooking time in min.	Comments
Bread rolls (50 - 100 g/piece)	solid	180 - 200	80 - 100	15 - 25	Another very good way of baking bread rolls is to preheat the appliance to 220 °C at 30% humidity. After placing the items to be baked into the appliance, inject additional steam once or twice, and after 5 minutes, switch back to 0% humidity and 190 °C.
Bread rolls, pre-baked	Wire rack	150 - 170	0	8 - 15	Inject steam at the beginning.
Bread (0.5 - 1 kg)	solid	1) 210 - 230	30	15 - 20	Inject steam 2 - 3 times at the beginning.
		2) 165	0	35 - 50	Use the core temperature probe to check the exact cooking temperature (see section entitled 'Core temperature sensor'). Place on the wire rack to cool.
Sponge tarts	solid	160 - 165	0	35 - 40	
Ring cake (1 kg flour)	Ring cake tin, wire rack	160 - 175	30	45 - 50	
Yeast tray bakes	solid	160 - 170	0 - 60	30 - 45	For yeast tray bakes with moist toppings (e.g. plum tart or onion tart), use 0% humidity, and for yeast tray bakes with dry toppings (e.g. crumble), use 60% humidity.
Plaited loaf (500 g flour)	solid	160 - 170	60 - 80	25 - 35	
Muffins	Muffin tray, wire rack	170 - 180	0 - 30	20 - 30	
Macaroons	solid	150 - 160	0	15 - 20	
Biscuits	solid	150 - 175	0	10 - 20	
Quiche, flan	Quiche dish or tin, wire rack	190 - 210	0	45 - 60	
Sponge cake	Loaf tin/ springform cake tin, wire rack	165 - 170	0 - 30	60 - 65	
Small cakes	solid	160	0	30	
Whirls (in accordance with EN60350-1)	solid	165	0	30 - 32	Preheat
Tart	Tart dish or tin, wire rack	190 - 200	0 - 30	30 - 45	E.g. with apples, chocolate, apricots, or savoury with asparagus, onions, cheese
Hot water sponge cake (in accordance with EN60350-1)	solid	150	0	40	Preheat
Cream puffs, eclairs	solid	180 - 190	0 - 30	40 - 45	

## Raising dough

- The combi-steam oven provides the ideal conditions for proving dough and dough mixtures or raw pastries without them drying out.
- To do this, use the "Hot air + 60% humidity" mode.
- The bowl does not need to be covered by a wet cloth. Proving only takes half as long as it usually does.
- The cooking time specified is intended as a guide only. Leave the dough to rise until it has doubled its volume.

Food	Cooking container	Temperature in °C	Humidity in %	Cooking time in min.	Comments
Dough mixture (600 g flour)	Bowl/wire rack	38 - 40	60	30 - 45	E.g. yeast dough, natural fermentation starter, sourdough

## Regenerating (reheating)

- In the steam oven, you can generate the optimum climate for heating ready-cooked meals without them drying out. Thus, taste and quality are preserved, and meals taste like freshly prepared.
- Use the "Regenerating" mode  to do this.
- The data refers to portions for one person. You can also warm up large quantities in the unperforated cooking container. The specified times are lengthened.

Food	Cooking container	Temperature in °C	Cooking time in min.	Comments
Baguette, bread rolls (frozen)	Wire rack	140	10 - 15	
Baguette, bread rolls (left over from previous day)	Wire rack	180	5 - 8	
Roasts, sliced (150 g/piece)	solid	120	12 - 15	Finger-thick slices, do not pile them on top of one another; pour sauce into the cookware to make the roast more succulent.
Vegetables	Dish, wire rack	90 - 100	8 - 10	
Pizza, thin	Wire rack	180	10 - 12	
Pizza, deep pan	Wire rack	180	12 - 14	
Starchy side dishes	Dish, wire rack	120	7 - 8	E.g. pasta, potatoes, rice; baked or fried food such as chips or croquettes are not suitable.
Plated meals	Dish, wire rack	120	8 - 15	

## Defrosting

- In the steam oven you can gently and evenly defrost deep frozen food faster than at room temperature.
- Use the "Defrosting" mode \* to do this.
- The specified defrosting times are only a recommendation. The time it takes to defrost depends on the size and weight of the frozen food: freeze your food flatly or individually. This shortens the defrosting time.
- Remove the packaging before defrosting.
- Defrost only the quantity you need for preparation.
- Remember: once defrosted, food will not keep for as long and spoils more quickly than fresh food. Immediately process defrosted food and cook it thoroughly.







- After half of the defrosting time, turn meat or fish over. Separate frozen pieces of food such as berries or bits of meat. It is not necessary to fully defrost fish. It will be sufficiently thawed if the tissue is soft enough to absorb the spices.

### Health risk!

When defrosting food from animal sources, you must remove the liquid that escapes during defrosting. It must never come into contact with other food. Bacteria could be transferred.

Slide the unperforated cooking container underneath the food. Pour away the collected thawing liquid from meat and poultry. Then clean the sink and rinse with plenty of water. Clean the cooking container in hot soapy solution or in a dishwasher.

After defrosting, operate the steam oven for 15 minutes using Hot air at 180°C.

Food	Cooking container	Temperature in °C	Type of heating	Cooking time in min.	Comments
Berries (300 g)	Perforated	45 - 50	* 	4 - 6	
Roasts (1 - 1.5 kg)	Perforated	45 - 50	* 	80 - 110*	
Fish fillet (150 g/piece)	Perforated	45 - 50	* 	8 - 12*	
Vegetables (400 g)	Perforated	45 - 50	* 	6 - 8	
Goulash (600 g)	Perforated	45 - 50	* 	30 - 45*	
Chicken (1 kg)	Perforated	45 - 50	* 	45 - 60*	
Chicken thighs (400 g/piece)	Perforated	45 - 50	* 	30 - 35*	

\* For this food, you need to include a compensation period: Once the defrosting time has elapsed, switch off the appliance and leave the food to rest in the appliance for a further 10 - 15 minutes with the door closed so that it has a chance to defrost right through to the very centre.

## Preserving

- It is easy to preserve fruit and vegetables in the combi-steam oven.
- Cook food as soon as possible after purchase or after it has been harvested. Prolonged storage reduces the vitamin content and means that food is on the verge of fermenting.
- Only use fruit and vegetables that are in good condition.
- The combi-steam oven is not suitable for preserving meat.
- Carefully check and clean the preserving jars, rubber sealing rings, clips and springs.
- Sterilise the washed jars in your combi-steam oven for 20-25 minutes at 100 °C and 100% humidity before preserving.
- Place the preserving jars in the perforated cookware. They must not be in contact with each other.
- Once the cooking time has elapsed, open the cooking compartment door. Do not remove the preserving jars from the cooking compartment until they have completely cooled down.

Food	Cooking container	Temperature in °C	Humidity in %	Cooking time in min.	Comments
Fruit, vegetables (in sealed 0.75 l preserving jars)	Perforated	100	100	35 - 40	
Beans, peas (in sealed 0.75 l preserving jars)	Perforated	100	100	120	

## Extracting juice (soft fruit)

- You can effortlessly and cleanly extract berry juice in the steam oven.
- Place the berries in the perforated cooking container and slide it into the third level from below. Slide in the unperforated cooking container one level below it to collect the juice.
- Leave the berries in the appliance until no more juice appears.
- Finally, place the berries in a cloth and squeeze out the rest of the juice.

Food	Cooking container	Temperature in °C	Humidity in %	Cooking time in min.	Comments
Berries	perforated + solid	100	100	60 - 120	

## Preparing yoghurt

- Even yoghurt can be prepared in the combi-steam oven.
- Heat pasteurised milk to 90 °C on the hob to prevent the yoghurt cultures from being overcome by any unwanted microbes. Ultra-heat treated milk (UHT milk) does not need to be heated. (Please note: If you use cold milk to make yoghurt, the incubation time will be longer).
- Important! Allow the milk to cool to 40 °C in a water bath so that the yoghurt cultures are not destroyed.
- Stir some natural yoghurt with identified yoghurt cultures under the milk (1 - 2 teaspoons of yoghurt per 100 ml).
- When using yoghurt starter, follow the instructions on the packet.
- Pour the yoghurt into washed jars.
- You can sterilise the washed jars in your combi-steam oven at 100 °C and 100% humidity for 20 - 25 min before pouring in the yoghurt. Make sure that you allow the jars and the cooking compartment to cool down before you pour in the yoghurt and place the jars in the appliance.
- Once you have finished making the yoghurt, place it in the refrigerator.
- To make thick yoghurt, add skimmed milk powder to the milk before heating it (1 - 2 tablespoons per litre).

Food	Cooking container	Temperature in °C	Humidity in %	Cooking time in min.	Comments
Yoghurt mixture (in sealed jars)	solid	40 - 45	100	300 - 360	Recipe tip: Flavour the yoghurt mixture with fruit purée, jam, honey, vanilla or chocolate, and then increase the preparation time if necessary.

## Preparing bulky food

- To prepare bulky food items, you can remove the side slide-in racks.
- To do this, undo the knurled nuts at the front of the slide-in racks, and pull the slide-in racks out towards you.
- Place the rack directly onto the bottom of the cooking compartment and place the food or roasting dish onto the rack. Do not place the food or roasting dish directly onto the bottom of the cooking compartment.

## Acrylamide in foodstuffs

Which foods are affected?

Acrylamide is mainly produced in grain and potato products that are heated to high temperatures, such as crisps, chips, toast, bread rolls, bread, fine baked goods (biscuits, gingerbread, cookies).

---

### Tips for keeping acrylamide to a minimum when preparing food

---

General	Keep cooking times as short as possible. Cook food until it is golden brown, but not too dark. Large, thick pieces of food contain less acrylamide.
Baking	With hot air at max. 180 °C.
Biscuits	Egg or egg yolk reduces the production of acrylamide. Spread out a single layer evenly on the baking tray.
Oven Chips	Cook at least 400 g at once on a baking tray so that the chips do not dry out.

---

**Gaggenau Hausgeräte GmbH**  
Carl-Wery-Straße 34  
D-81739 München  
[www.gaggenau.com](http://www.gaggenau.com)

**GAGGENAU**



9000974168 en (950707)