

ONDA inox

Caratteristiche generali

Acciaio inox (AISI 304) spazzolato. Filtro antigrasso metallico, asportabile e lavabile. Filtro carbone. Pulsantiera elettronica.

General features

Scotch brite Stainless steel (AISI 304). Metallic grease filter, removable and washable. Charcoal filter. Electronic optical control.

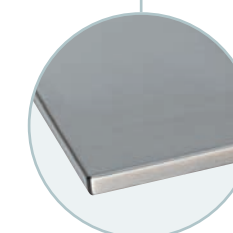
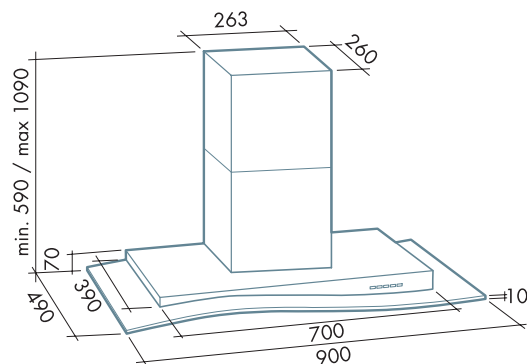

Pannello acciaio inox AISI 304
10 mm di spessore
10 mm thickness scotch brite
stainless steel AISI 304 panel



isola/island

/

/

/



parete/wall

/

90

/

motore e comandi / motor and control

450 m³/h 3 vel.

600 m³/h 3 vel.

800 m³/h 4 vel.

filtri / filters

"Base"

"Top"

carbone/charcoal

illuminazione / lighting



Halogen lamp



Dicroica lamp



Incandescent lamp



Fluorescent lamp

ACCESSORI OPZIONALI DISPONIBILI: Aspiratore sottotetto (solo versione 800 m³/h) - Aspiratore esterno (solo versione 800 m³/h) - Prolunga camino parete - Salvietta *Magic Steel*

AVAILABLE OPTIONAL ACCESSORIES: Under-roof extractor fan (only 800 m³/h version) - Outdoor extractor fan (only 800 m³/h version) - Wall chimney extension - *Magic Steel* protective and cleaning wipe

ONDA inox

Design

^{new}
600 800

AISI 304

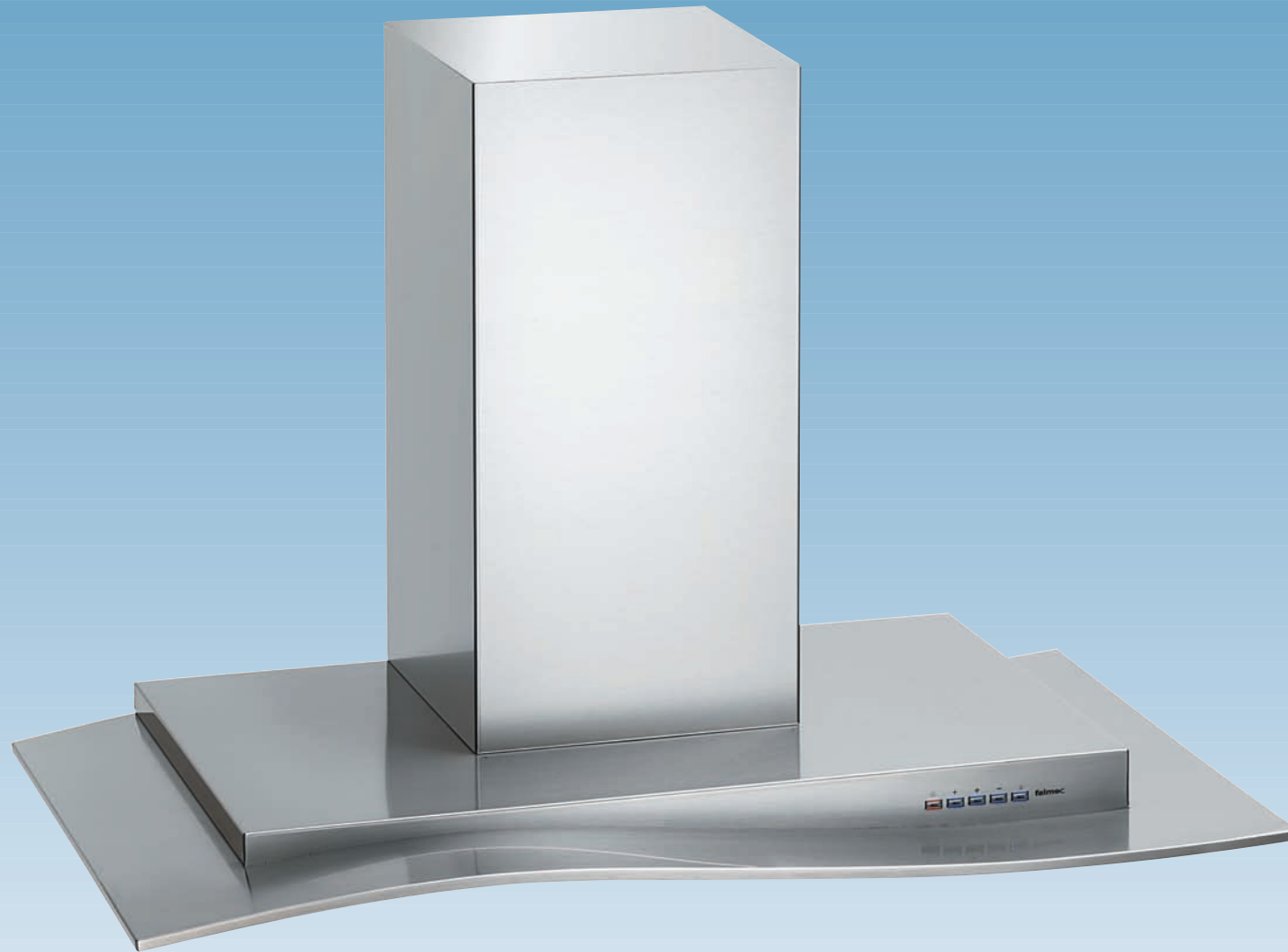

Design