

EN GUIDE TO INSTALLATION AND USE

Cooking Hob

DTI1031X Induction Modular Hob

Dear Customer,

You have just acquired a DE DIETRICH hob and we would like to thank you.

In order to offer you an excellent product, our research teams have created this new generation of appliances for you. Their quality, appearance, functions and technological advances make them exceptional products, showcases of our unique know-how.

In the line of DE DIETRICH products, you will also find a wide range of ovens, microwaves, ventilation hoods, hoods, dishwashers, and refrigerators, all of which can be integrated and all of which can be coordinated with your new DE DIETRICH hob.

Of course, in our ongoing desire to ensure our products satisfy your needs in the best possible way, our customer service department is always at your disposal at our site.

www.dedietrich-electromanager.com

DE DIETRICH
Setting New Values

We are constantly improving our products; for this reason we reserve the right to make all modifications to their technical, functional or aesthetic characteristics, originating from technical developments.



Warning

Before installing and using your appliance please read this installation and use the guide carefully - it will help you familiarise yourself very rapidly with its operation.

1 / INSTALLING YOUR APPLIANCE	
• Installation _____	4
• Connection _____	5
2 / USING YOUR APPLIANCE	
• The induction principle _____	6
• Description of your top _____	7
• Using a cooking zone _____	8
• Additional functions _____	8
Preheating	
Function Boil	
Independent timer	
Elapsed time	
Child safety	
Clean lock	
• Safety features when operating _____	10
3 / MAINTAINING YOUR APPLIANCE _____	11
4 / SPECIAL MESSAGES, DIFFICULTIES _____	12
5 / AFTER-SALES SERVICE _____	13

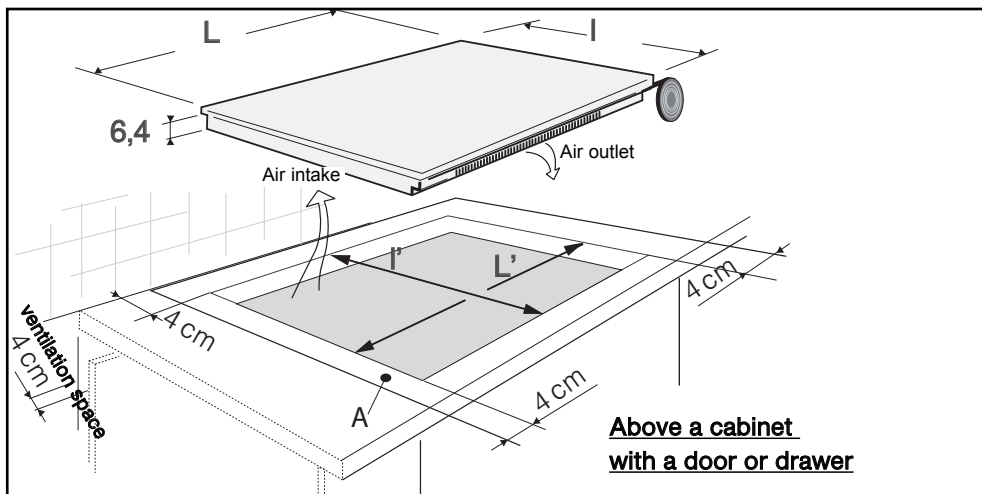

• CHOOSING THE POSITION

The distance between the edge of your appliance and the side and rear walls (or partitions) must be at least four centimetres (zone A).

Your appliance may be built in without any restriction. Check, however, that the air intake and outlet are free of obstruction (see "description of your appliance" chapter).

The building-in method opposite is recommended for use above an oven or a built-in appliance.

• BUILDING-IN

Follow the diagram above.

Glue the foam seal underneath your appliance, following the perimeter of the hole in the worktop, upon which your appliance will rest. This will ensure a good seal against the worktop.

Attach the clips to the hob (depending on the model).

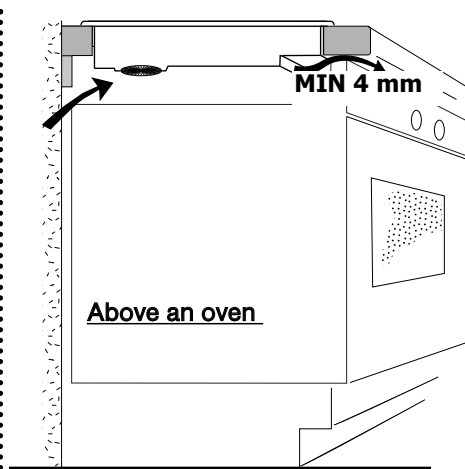

Tip

If your hob is located above your oven, the hob's thermal safety devices can impede the simultaneous use of the hob and the oven's pyrolysis program.

Your hob is equipped with an anti-overheating safety system.

This safety device can trigger, for example, when the hob is installed over an oven that is not sufficiently insulated. If this occurs, a series of small lines appears on the control panel. In such circumstances we recommend that you increase the hob's ventilation by creating an opening in the side of the cabinet, (8 x 5 cm), and/or installing an oven insulation kit available from the after-sales department.

Connection

These hobs must be connected to the mains using a socket in compliance with publication CEI 60083 or an all-pole circuit-breaker device in compliance with the installation rules in force.

When power is first supplied to your hob, or after an extended power cut, an indicator light will appear on the control panel. This information will disappear after 30 seconds.

DTI731X

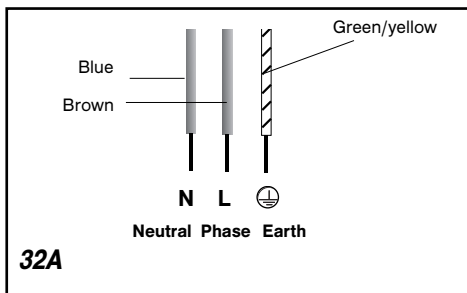

Warning

If the cable is damaged it must be replaced by the manufacturer, its after-sales service or a person with a similar qualification to prevent danger.

We have designed this cooking hob for use by private individuals in their homes.

These cooking hobs are intended exclusively for cooking beverages and foodstuffs and do not contain any asbestos-based materials.

This appliance is not intended to be used by persons (including children) with reduced physical, sensory or mental abilities, or persons lacking experience or awareness, unless using it with the help of a person responsible for their safety, or under supervision and with prior instruction in its use. Children should be supervised to ensure that they do not play with the appliance.

• *The induction principle*

The principle of induction is based on a magnetic effect.

When you place your cookware on a cooking zone and you turn it on, the electronic circuits in your cooking hob produce “induced” currents in the bottom of the cookware which instantly raise its temperature. This heat is then transmitted to the food

To help you choose, a list of cookware is provided with this guide.

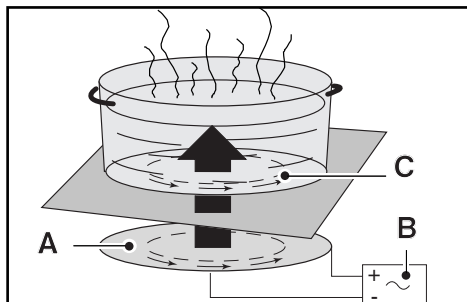

A - Induction plate

B - Electronic circuit

C - Induced currents

• *Cookware*

Most cookware is compatible with induction.

To verify that your cookware is suitable, place it on a heating area (16 or 23cm) on power 4.

- If the display remains on, your cookware is compatible.

- If the display flashes, your cookware cannot be used with induction cooking.

You can also use a magnet to test the cookware.

If a magnet “sticks” to the bottom of the cookware, it is compatible with induction.

Only glass, terra cotta, aluminium without a special finish on the bottom, copper and some non-magnetic stainless steels do not work with induction cooking. We recommend that you select cookware with a thick, flat bottom. When you buy your cookware, make sure that this logo is on the package; it assures you that it is compatible with induction cooking.

• *Choosing a cooking area*

Cooking area	Diameter of base of cookware
28 cm	12 32 cm

CLASS
INDUCTION

Description of your top

DTI1031

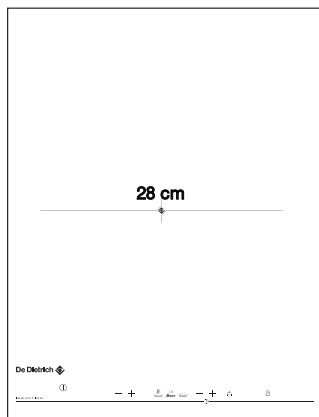
**Total dimensions (L x l)**

DTI1031X : 38 x 52

Recess cut-out (L' x l')

DTI1031X : 34 x 49

Power :

DTI1031X : 4600W

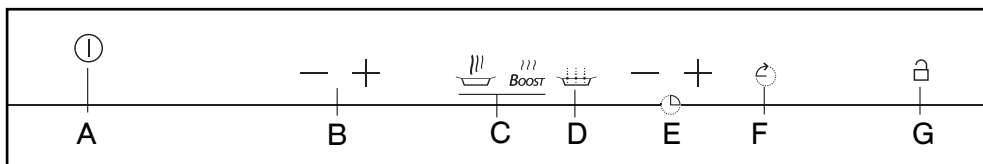

The ① button is used to switch the cooking zone on or off.

• Adjustment touch controls

The touchpads allow you to adjust power, timer, programmer...

- B** adjusting the power
- C** preselecting the power
- D** function *Boil*
- E** adjusting the timer
- F** function *ELAPSED TIME*
- G** locking - unlocking - Clean lock

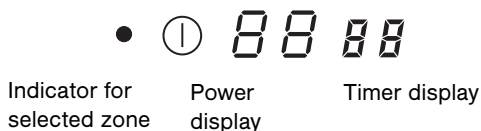

If there is no cookware on the selected zone, your adjustments will delete automatically after a few moments.

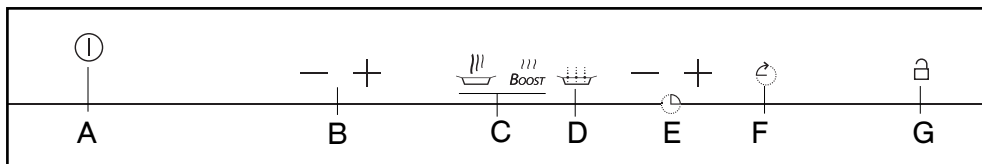

Using a cooking zone

Adjusting the power level:

- Place your cookware on the cooking zone and press the corresponding touchpad **A**.

A beep and a light will confirm your selection.

- Adjust the power with touchpads **B**, **C**.

- Pressing the touchpad  several times allows you to access preselected power levels (4 - 8 - 15).

Switching off a cooking zone

- Hold you finger down on touchpad **A**

Adjusting the timer:

- **Adjust the timer using touchpad D.**

- When cooking is finished, "0" is displayed and a beep sounds. Press touchpad **A**.

Note :

- The first touch on **E** "-" directly selects 99 minutes.

- Simultaneous touch on **E** "+" and "-" cancels the timing in progress.

- If you do not make a selection or if there is no cookware, the selected zone turns off after a few moments.

Additional functions

• Preheating

This function allows a higher temperature to be reached more rapidly, followed by an automatic return to cooking power.

- Switch on the cooking zone.

- Turn on preheating with the touchpad **B** "-", **HU** is displayed on your hob.

- Pre-adjust the cooking power with touchpad **B** (higher than 6). A beep will confirm your adjustment after a few moments. Cooking starts.

- During the pre-heating stage, **HU** and the cooking power display alternately.

- After the pre-heating stage, your hob displays the cooking power.

Note:

- The pre-heating time is calculated automati-

cally by your hob depending on the power level chosen.

- When **HU** is displayed, if you do not adjust the cooking power, the zone turns itself off after a few moments.

• BOIL

This function allows water to be boiled and kept at boiling point to cook any food that requires boiling.

- Give a short press on button **D**. You will hear a short beep. "2l" (2 litres) is displayed as the default.

- Adjust the volume of water to between 0.5 and 6 litres, using the + and - buttons (**B**). The quantities of water are 0.5l, 1l, 1.5l, 2l, 2.5l, 3l, 4l, 5l and 6litres.

- Give a short press on button **D** to confirm the selection. A short beep sounds and the "boil" display stops flashing.

Once the water has boiled, a series of beeps is heard and the word "boil" scrolls through the display (b, then o, etc...)

- add the food (pasta, rice etc.). Give a short press on button **D**. Power 12 or 13 and 1 min is displayed by default.

Adjust the time, using the buttons **E**. If you wish, you may alter the power via the buttons **B**.

The settings are confirmed automatically after a few seconds or by pressing button **D**. A short beep sounds.

NOTE: It is important that the water temperature is neither too hot nor too cold when cooking begins, as this could affect the final result.

This function may be used on all cooking zones at the same time.

Do not use cast iron cookware.

Do not use a lid.

Do not use salt.

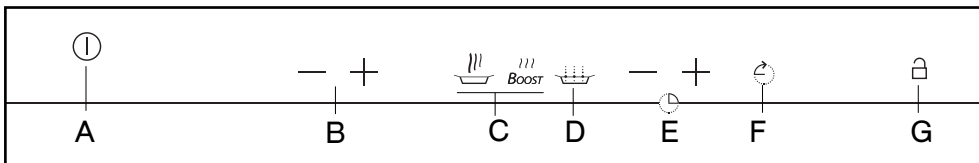

•Independent timer

This function allows you to time an event, without cooking.

- Select a cooking zone you are not using.
- Set the time with touchpad **E**. A “t” flashes in the display.
- At the end of your adjustment “t” becomes becomes fixed and the count begins.

Note:

You can stop a count in progress by keeping your finger on the touchpad of the selection on the display.

•Elapsed time

This function displays the time elapsed since the last power setting adjustment on a chosen zone.

To use this function, press the **F** button. The elapsed time flashes on the timer display of the selected zone.

If you want cooking to end in a specific period, press button **F** then, in 5 seconds, press “+” on the timer to increase the cooking time that you wish to set. The time display becomes steady for 3 seconds then the remaining time is displayed. There is a beep to confirm your choice.

This function exists with or without the timer function.

Note: If a time is displayed on the timer, this time cannot be changed during the 5 seconds after pressing the **F** button. Once these 5 seconds have elapsed, you may change your cooking time.

•Child safety

This function allows you to lock your hob when it is shut off or when it is cooking.

To lock:

- Keep your finger on touchpad **G**. A beep sounds and an indicator appears. The indicator will go out automatically after a few moments.

To unlock:

- Keep your finger on touchpad **G**. A beep sounds and the indicator goes out.

Note:

- In locked mode, any action will produce a key symbol on the display. You must unlock your hob before using it.
- If you activate the lock while cooking, the stop display will be prioritised on the lock.

•Clean lock

This function allows you to temporarily lock your hob while cleaning.

To activate Clean lock:

- Your cooking hob must be turned off.
- Briefly press touchpad **G**. A beep sounds and an indicator appears.
- After a predefined time, the lock will automatically disengage. A beep sounds and the indicator goes out.



As shown in this logo, the materials used to package this appliance are not recyclable. Recycle them and play a role in protecting the environment by depositing them in municipal containers provided for this purpose.

Recycling of the appliances organised by your manufacturer will thus be undertaken in optimum conditions, in accordance with European directive 2002/96/CE relating to electrical and electronic equipment waste. Contact your local authority or retailer for how to have used appliances collected or collection points.

Safety when operating

• Residual heat

After a long cooking period, the zone used can remain hot for several minutes. An “H” flashes during this period. Do not put your hand on the zone.

• Temperature limiter

Each cooking zone is equipped with a safety sensor that constantly monitors the temperature of the bottom of the cookware. If you leave empty cookware on a zone which is turned on, it will automatically limit the power in order to prevent damage to the cookware or hob.

• Protection against overflows

In case of overflow, or of a metallic object or wet cloth placed on the control areas, the hob turns itself off, the displays light up and a beep sounds. Clean the hob or remove the object, then begin cooking again.

• For users with heart pacemakers and active implants.

The functioning of the hob conforms to current electromagnetic interference standards and thus is in total compliance with legal requirements (89/336/EEC directives).

In order to avoid interference between your cooking hob and a pacemaker, your pacemaker must be designed and programmed in compliance with the regulations that apply to it.

As we can guarantee the compliance only of our own products, we strongly recommend that you refer to the maker of your device or to your doctor to avoid possible incompatibilities.

• Auto-Stop system

If you forget cooking is in progress, after a predefined time, this safety function will automatically turn off your hob (from 1 to 10 hours depending on the power setting). “AS” displays and a beep sounds after about 2 minutes. Press on the main selector to delete this information. A beep will confirm your setting.

• “Small Items” safety

If you place a small object on the area (a ring, a fork, etc), the hob will detect it and not deliver any power. The power display flashes.

Note:

However, several small objects at the same time on a zone could be identified as cookware. In that case, power will be delivered by the hob.



Do not place any utensils (spoons, forks, covers, etc) on the cooking zone being used. They will heat up in the same way as cookware:

Risk of combustion.

Preserve your appliance

The vitroceramic glass surface is highly resistant, but not unbreakable. Here are some recommendations for increasing its lifetime:

- Avoid banging or clattering the cookware.
- Avoid putting heating covers on the hob. A suction effect may damage the vitroceramic surface.
- Do not use cookware with bottoms that are rough or dented.
- Do not use your cooking hob as a work surface.
- Never use aluminium foil or paper or aluminium scrubber to clean it. The aluminium melts and damages the top.
- Never use a steam cleaner to clean your hob.

- Never directly reheat a tin can. It will have a risk of exploding.

Aesthetic faults, as a result of mistreatment of your hob and which do not entail a lack of function, are not covered by our guarantee.

And for the safety of your kitchen, do not place cleaning items or inflammable objects or products in the kitchen furniture underneath your cooking hob.

Maintaining your appliance

TYPES OF STAINS/SPOTS	USE	WHAT TO DO?
Light.	Cleaning sponges	Thoroughly moisten the zone to be cleaned with hot water, then wipe off.
Accumulation of baked-on stains/dirt. Sugar spills, melted plastics.	Cleaning sponges Scraper for glass.	Thoroughly moisten the zone to be cleaned with hot water. Use a scraper for glass to remove the large bits, follow with the rough side of a disinfectant sponge, and then wipe off.
Rings and hard water residue.	White vinegar.	Apply warm white vinegar to the stain, let stand, then wipe with a soft cloth.
Shiny metal colourings. Weekly maintenance.	Special vitroceramic glass product.	Apply a cleaning agent for vitroceramic glass (preferable one with silicon for its protective properties) to the surface.



cream



cleaning sponge
special for delicate crockery



powder



abrasive sponge



• On first use

	<i>POSSIBLE CAUSES:</i>	<i>WHAT SHOULD YOU DO?</i>
A special lamp appears.	Working normally.	Nothing, the light disappears after 30 seconds.
Your installation blows a fuse.	The electrical connection of your hob is incorrect.	Check that it is set up properly. See the “Electrical Connection” section.
Only one side works.		
The hob produces an odour during the first cooking sessions.	New appliance.	Nothing. The smell will disappear after several uses.

• On switching on

<i>YOU OBSERVE THAT:</i>	<i>POSSIBLE CAUSES:</i>	<i>WHAT SHOULD YOU DO?</i>
The hob does not operate and the indicator lights on the control panel do not light up.	The machine is not connected to the power source. The power source or connection is defective.	Inspect the electrical circuit breaker and fuses.
The hob is not working and another message is displayed.	The electronic board is functioning poorly.	Call the After-Sales Service Department.
The hob does not function, the information  is displayed.	The hob is locked	See chapter on using the child safety system

• While in use

<i>YOU OBSERVE THAT:</i>	<i>POSSIBLE CAUSES:</i>	<i>WHAT SHOULD YOU DO?</i>
The hob has stopped operating and is beeping approximately every 10 seconds and a  or F7 is displayed.	There was an overflow or an object is in contact with the control panel.	Clean the hob or remove the object, then begin cooking again.
A series of small  or F7 is displayed.	The electronic boards heated up.	See “Inserting” section.
After turning on a heating zone, the indicator lights on the control panel continue to flash.	The cookware used is not suitable for induction or is less than 12 cm in diameter (10 cm on a 16 cm area).	See section on cookware for induction.
The saucepans make noise during cooking. Your hob makes a clicking sound during cooking.	This is normal with some types of cookware. This is caused by the transfer of energy from the hob to the cookware.	Nothing. There is no risk, neither to your hob nor to your cookware.
The fan continues to function a few minutes after your hob is turned off.	Cooling of the electronic components. Working normally.	Nothing.
After turning on a heating zone, the indicator lights on the control panel remain steady but the cookware is not heated.	The cookware used is not suitable for use with induction.	See section on cookware for induction.

Any maintenance on your equipment should be undertaken by:

- either your dealer,
- or another qualified mechanic who is an authorized agent for the brand appliances.

When making an appointment, state the full reference of your equipment (model, type and serial number). This information appears on the manufacturer's nameplate attached to your equipment.

For UK after sales service information please contact:-

www.dedietrich.co.uk

De Dietrich UK office – tel: 01256 308000



In case of breakage, cracks or even light fissures in the vitroc ceramic glass, take out the fuses or turn off the circuit breaker for your hob to avoid the risk of electrical shock.

Contact the After-Sales Service Department.

DE DIETRICH COOKING PRODUCT WARRANTY

1. Subject to the "Statement of Standard Warranty Conditions" this product is covered by the following Warranty.

TWO (2) YEARS WARRANTY from date of purchase, covering all parts and labour.

2. The appliance is warranted under normal single family domestic installation and use, as set out in the instruction manual, against manufacturing defects for the Warranty periods shown above.
3. Should service be required under this Warranty, the purchaser should contact an approved DE DIETRICH Service Provider during their normal business hours.
4. At no time does DE DIETRICH/MEA have liability for any freight or transportation costs or for any damage during transit or for any consequence of failure of this appliance outside of the normal service area, unless such limitation of liability is prohibited by statute.
5. This Warranty excludes replacement of parts required due to normal wear and tear including light globes.
6. This Warranty only applies, provided the appliance has been used in accordance with the manufacturer's instructions and provided an accident, misuse, neglect or abuse has not damaged the appliance.
7. None of the above Warranties purport to exclude, restrict or modify either the application or the exercise of a right conferred by any applicable Statute.
8. Please complete the details below, which should be retained for future reference along with your proof of purchase:

Date of Purchase:

Model No:

Serial No:

MEA0702

STATEMENT OF STANDARD WARRANTY CONDITIONS

1. The Warranty only applies provided that the appliance has been used in accordance with the manufacturer's instructions and provided that the appliance has not been damaged by an accident, misuse, neglect or abuse of any person other than the manufacturer or DE DIETRICH/Major Electrical Appliances ("MEA") or from faulty installation, mis-adjustment or tampering by unauthorised persons.
2. When a service inspection reveals the alleged fault or faults are caused by incorrect operation, contrary to the instruction manual, and otherwise the appliance is in good order and working condition, the purchaser shall be liable for a service fee charged by DE DIETRICH/MEA or one of its' Service Providers.
3. If the appliance is used in Commercial Applications or for Rental purposes, a separate warranty of Twelve (12) months covering all parts with Three (3) months on the labour will apply.
4. Subject to the provisions of any applicable statute this Warranty applies to the original retail purchaser only and is not transferable.
5. Subject to the provisions of any applicable statute, at no time does DE DIETRICH/MEA have liability for freight, transport or travel costs outside normal service areas.
6. None of the above Warranties purport to exclude, restrict or modify either the application or the exercise of a right conferred by any applicable statute.
7. Subject to any Warranties implied by statute, at no time will DE DIETRICH/MEA or its' Service Providers be liable for any economic loss consequent upon the failure of the appliance.
8. This Warranty is only valid for major appliances imported and distributed by DE DIETRICH/MEA, purchased and used in Australia.

