

1. Precautions for safety and use	20
2. Fitting the appliance in the top	21
2.1 Fixing to the supporting structure	21
2.2 Fitting the gasket	22
2.3 Fixing using brackets	22
3. Electrical connection	23
4. Gas connection	24
4.1 Bottled gas connection	24
4.2 Room ventilation	24
4.3 Combustion gas discharge	24
5. Adapting to different types of gas	25
5.1 Removing the hob skin	25
5.2 Adjusting for bottled gas	26
5.3 Adjusting for natural gas	27
5.4 Adjusting the primary air flow	27
5.5 Reassembling the hob skin	28
5.6 Adjusting the minimum for natural gas	28
5.7 Adjusting the minimum for bottled gas	28
5.8 Hob burner layout	28
5.9 Greasing the gas taps	28
6. Description of controls	29
6.1 The front panel	29
7. Using the hob	30
7.1 Fitting the Pan Stands	30
7.2 Lighting burners with safety device	32
7.3 Practical hints for using the burners	32
7.4 Pan diameters	33
8. Cleaning and maintenance	34
8.1 Cleaning the hob	34
8.2 Cleaning the components	34

THESE INSTRUCTIONS ONLY APPLY TO THE COUNTRIES OF DESTINATION WHOSE IDENTIFICATION SYMBOLS ARE LISTED ON THE COVER OF THIS MANUAL.
THIS BUILT-IN HOB IS CLASSIFIED AS CLASS 3.



INSTRUCTIONS FOR THE INSTALLER: these are intended for the **qualified engineer** who is to check the gas supply system and install, commission and test the appliance.



INSTRUCTIONS FOR THE USER: these provide recommendations for use, a description of the controls and the correct procedures for cleaning and maintaining the appliance.

1. Precautions for safety and use



THIS MANUAL IS AN INTEGRAL PART OF THE APPLIANCE. TAKE GOOD CARE OF IT AND KEEP IT TO HAND THROUGHOUT THE HOB'S LIFE CYCLE. USERS ARE ADVISED TO READ THIS MANUAL AND ALL THE INSTRUCTIONS IT CONTAINS BEFORE USING THE HOB. ALSO KEEP THE SET OF NOZZLES PROVIDED IN A SAFE PLACE. INSTALLATION MUST BE CARRIED OUT BY QUALIFIED STAFF IN COMPLIANCE WITH THE RELEVANT REGULATIONS. THIS APPLIANCE IS INTENDED FOR HOUSEHOLD USE AND COMPLIES WITH THE **EEC DIRECTIVES** CURRENTLY IN FORCE. THE APPLIANCE IS BUILT TO PROVIDE THE FOLLOWING FUNCTION: **COOKING AND HEATING FOODS**; ALL OTHER USES ARE TO BE CONSIDERED IMPROPER.

THE MANUFACTURER DECLINES ALL LIABILITY FOR USES OTHER THAN THOSE STATED ABOVE.



NEVER LEAVE PACKAGING RESIDUES UNATTENDED IN THE HOME. SEPARATE WASTE PACKAGING MATERIALS BY TYPE AND CONSIGN THEM TO THE NEAREST SEPARATE DISPOSAL CENTRE.



THE APPLIANCE MUST BE CONNECTED TO EARTH IN COMPLIANCE WITH ELECTRICAL SYSTEM SAFETY REGULATIONS.



THE PLUG TO BE CONNECTED TO THE POWER SUPPLY LEAD AND THE RELATIVE SOCKET MUST BE OF THE SAME TYPE AND COMPLY WITH THE RELEVANT REGULATIONS. THE POWER SUPPLY SOCKET MUST BE ACCESSIBLE EVEN AFTER THE APPLIANCE HAS BEEN BUILT-IN

NEVER DISCONNECT THE PLUG BY PULLING ON THE POWER SUPPLY LEAD.



IMMEDIATELY AFTER INSTALLATION, CARRY OUT A QUICK TEST ON THE HOB FOLLOWING THE INSTRUCTIONS PROVIDED LATER IN THIS MANUAL. IF THE APPLIANCE FAILS TO OPERATE, DISCONNECT IT FROM THE ELECTRICAL MAINS AND CONTACT YOUR NEAREST SERVICE CENTRE.

NEVER ATTEMPT TO REPAIR THE APPLIANCE YOURSELF.



AFTER EACH USE OF THE HOB, ALWAYS CHECK THAT THE CONTROL KNOBS ARE TURNED TO "ZERO" (OFF).



NEVER PLACE PANS WITH BOTTOMS WHICH ARE NOT PERFECTLY FLAT AND SMOOTH ON THE HOB PAN STANDS.



NEVER USE PANS OR GRIDDLE PLATES WHICH PROJECT BEYOND THE OUTSIDE EDGE OF THE HOB.



THE NAMEPLATE WITH THE TECHNICAL DATA, SERIAL NUMBER AND MARK IS IN A VISIBLE POSITION UNDERNEATH THE CASING, ANNEXED TO THIS MANUAL AND APPLIED TO THE QUALITY CERTIFICATE.

THIS NAMEPLATE MUST NEVER BE REMOVED.



THE APPLIANCE IS INTENDED FOR USE BY ADULTS. KEEP CHILDREN AT A SAFE DISTANCE AND NEVER ALLOW THEM TO PLAY WITH IT.



THIS APPLIANCE IS TAGGED UNDER EUROPEAN DIRECTIVE 2002/96/EC ON WASTE ELECTRICAL AND ELECTRONIC EQUIPMENT (WEEE).

THIS DIRECTIVE CONTAINS THE REGULATIONS GOVERNING THE COLLECTION AND RECYCLING OF DECOMMISSIONED APPLIANCES THROUGHOUT THE EUROPEAN UNION.



The manufacturer declines all responsibility for injury or damage caused by failure to comply with the above regulations or deriving from tampering with even just one part of the appliance and the use of non-original spare parts.



2. Fitting the appliance in the top



The procedures required below must be carried out by a skilled builder and/or joiner. The hob can be installed on various materials, including masonry, metal, solid wood and wood finished with plastic laminates, provided the material is heat-resistant (T 90° C).

2.1 Fixing to the supporting structure

Make a hole in the cabinet top with the dimensions shown here, maintaining a distance of at least **100 mm** from the rear edge. This appliance may be installed against walls higher than the worktop surface, provided the distance shown here is maintained, in order to prevent damage due to overheating. Make sure that there is at least **750 mm** between the hob burners and a shelf or hood (if any) placed vertically above them.

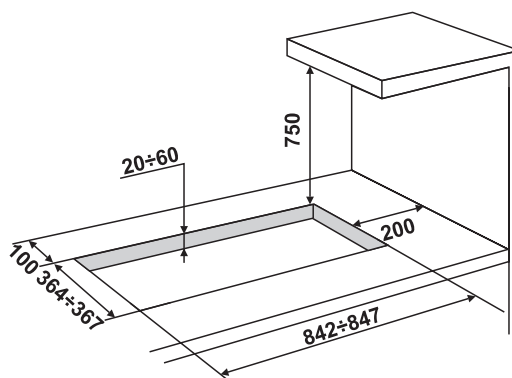

If the hob is installed above an oven, the oven must be fitted with a cooling fan.



If the hob is installed above a cupboard with doors, a separator panel must be installed underneath it. Leave a gap of at least 10 mm between the bottom of the hob and the surface of the panel, which must be easily removable to allow sufficient access for any servicing procedures.

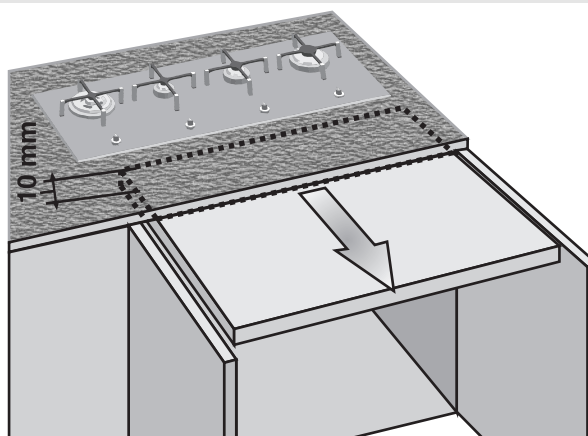



Instructions for the Installer

2.2 Fitting the gasket

Fit the insulating gasket provided carefully around the outside edge of the hole made in the top as shown below, pressing it down with your hands so that its entire surface fits snugly. Follow the dimensions shown, bearing in mind that the long front edge must be flush with the hole.

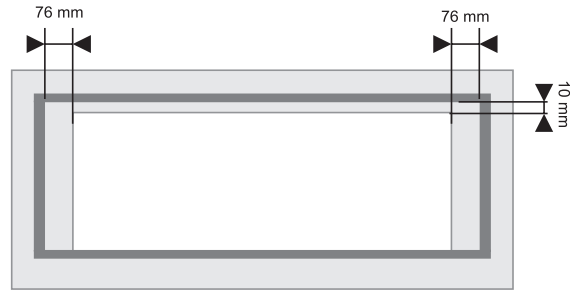

2.3 Fixing using brackets

Fix the hob to the structure using the brackets **A** provided. Carefully trim off the excess edge of the gasket **B**. The dimensions in the drawing below refer to the hole **on the inside edge** of the gasket.

See right for the precise holes to be used when securing the hob to the top correctly using the brackets.

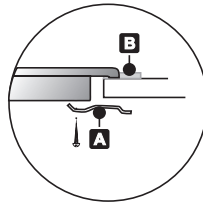
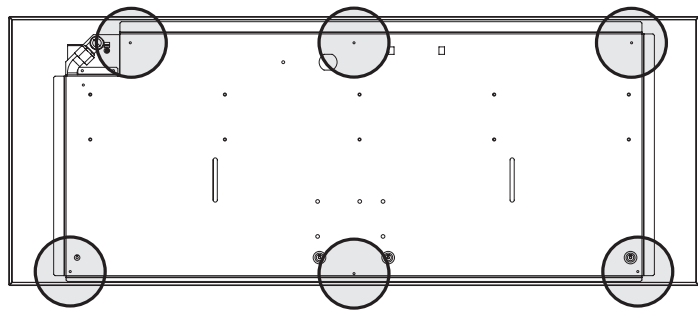



3. Electrical connection



Check that the power supply line voltage and size are as specified on the nameplate underneath the appliance's casing. **This nameplate must never be removed.**

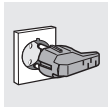

The plug on the end of the power supply lead and the wall socket must be of the same type and comply with the relevant regulations. Check that the power supply line is properly earthed.

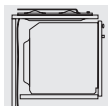

Pass the power supply cable through the rear of the cabinet, taking care that it does not touch the bottom case of the hob, or the oven (if any) built in underneath it.



The appliance's power supply line must be fitted with an omnipolar breaking device with contact gap of at least **3 mm**, located in an easily accessible position close to the appliance itself.

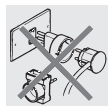

The use of reductions, adapters or junctions is not recommended.



If the power supply cable has to be replaced, the gauge of the wires in the new cable must be at least 0.75 mm^2 (3 x 0.75 cable), bearing in mind that the earth wire (yellow-green) must be at least 20 mm longer at the end for connection to the appliance. Use only a type H05V2V2-F or similar cable resistant to a temperature of up to 90°C . The cable must be replaced by a qualified electrician, who must make the mains connection as shown below.

L = brown

N = blue

 = yellow-green

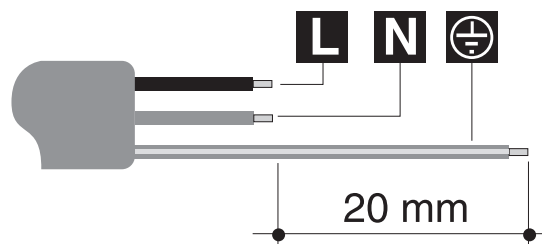

The power supply lead must be replaced by an authorised service centre to prevent all risks.



The manufacturer declines all responsibility for injury or damage caused by failure to comply with the above regulations or deriving from tampering with even just one part of the appliance.



Instructions for the Installer

4. Gas connection

If the appliance is installed above an oven, the gas hose must be passed around the back of the oven to prevent overheating.

The connection to the gas mains may be made using a copper pipe or a continuous-wall steel hose in accordance with the relevant regulations. To simplify connection, the horizontal position of the fitting **A** on the back of the appliance is adjustable. Undo the hexagonal nut **B**, turn the fitting **A** into the required position and re-tighten the hexagonal nut **B** (it has a rubber gasket to ensure it provides an effective seal). When installation is complete, check for any leaks with a soapy solution, never with a naked light. The appliance is tested with G20 (2H) natural gas at the pressure of 20 mbar. For use with other types of gas, see section "5 Adapting to different types of gas". The gas intake connection has an external 1/2" gas thread (ISO 228-1).

Connection with copper pipe: The connection to the gas supply mains must be made so that no stresses or strains of any kind are applied to the appliance. The connection can be made using the adapter unit **D** with two conical elements, always fitting the gasket **C** supplied.

Connection with steel hose: use only continuous-wall stainless steel hoses compliant with the relevant regulations, and always fit the gasket **C** supplied between the fitting **A** and the hose **E**.

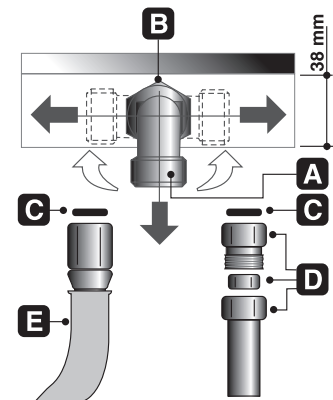

When connecting with a hose, ensure that the total length of the pipeline is not more than 2 metres; also ensure that the hoses do not touch moving parts and are not crushed.

4.1 Bottled gas connection



Use a pressure regulator and make the connection to the gas cylinder in accordance with the relevant regulations. Make sure that the gas supply pressure is as stated in the table in point "5.2 Adjusting for bottled gas".

4.2 Room ventilation



The appliance may only be installed in a permanently ventilated room as specified by the relevant regulations. The air flow into the room where the appliance is installed must be sufficient for proper gas combustion and room ventilation. The air intakes, protected by gratings, must be of suitable size (see relevant regulations) and located so that they cannot be even partially obstructed.

The kitchen must be kept properly ventilated to disperse the heat and humidity produced by cooking processes: in particular, a window should be opened or the speed of any fans increased after prolonged use.

4.3 Combustion gas discharge



Combustion gases must be discharged by means of hoods connected to a flue with reliable natural draught, or a fan extraction system. An effective extraction system requires careful design by an authorised specialist, and must comply with the regulation distances and positions. After installation, the engineer must issue a certificate of compliance.



5. Adapting to different types of gas



The operations described below must be carried out with the appliance not connected to the gas supply.

The appliance is tested with **G20 (2H) natural gas** at the pressure of 20 mbar. **If it is to be used with other types of gas, the burner nozzles have to be changed and the primary air flow adjusted.**

To replace the nozzles and adjust the burners, the hob skin has to be removed. Proceed as described below.

5.1 Removing the hob skin

Remove all the burner components in the numerical order shown below:

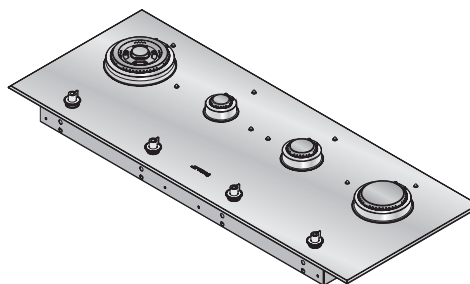

- Pull off all the knobs.
- Lift all the burner components off the hob.

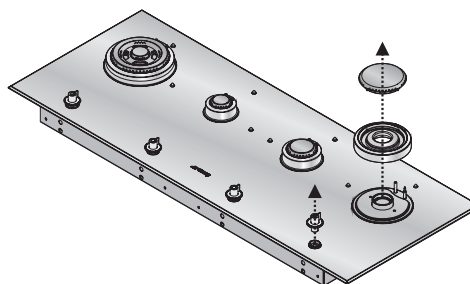

1

- Remove the hob skin fixing screws.

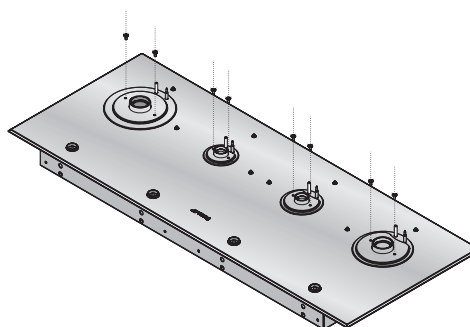

2

- After removing all the components described above, lift off the hob skin. Release all snap connections simultaneously (the hob is connected to the casing underneath in 5 points).

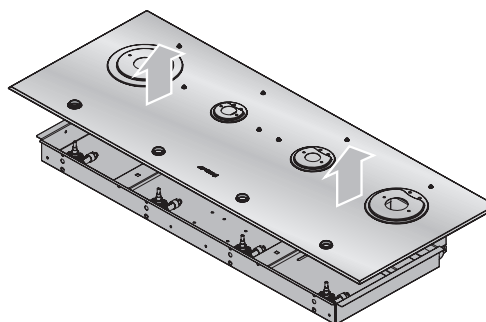

3



During reassembly, after putting the hob skin in position, press down on the points shown above to snap all the connections back into place.



Instructions for the Installer

5.2 Adjusting for bottled gas

Undo the screw **C** and push the air regulator **D** fully down.

Remove the nozzle **E** with a 7 mm spanner and fit the suitable one, following the instructions in the tables referring to the type of gas to be used. The nozzle must not be tightened with a torque of more than **3 Nm**.

Regulate the air flow by sliding the regulator **D** along until the distance "**X**" stated in point "0

Adjusting the primary air flow" is obtained.

Fix the regulator **D** by tightening the screw **C**.

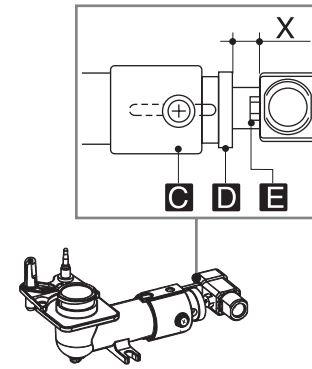

Burner	Rated heat capacity (kW)	Bottled gas – G30/G31 30/37 mbar				
		Nozzle diameter 1/100 mm	By-pass mm 1/100	Reduced heat capacity (W)	Flow rate g/h G30	Flow rate g/h G31
Auxiliary	1.05	48	30	400	76	75
Semi rapid	1.7	62	32	450	124	121
Rapid	3.0	82	50	1050	218	214
Ultra Rapid	4.2	98	63	1600	305	300



5.3 Adjusting for natural gas

The appliance is tested with G20 (2H) natural gas at the pressure of 20 mbar. To return the appliance to the condition required to use this type of gas, proceed as described in point “5.2 Adjusting for bottled gas” but select the nozzles and adjust the primary air flow for natural gas, as indicated in the table below and in point “5.4 Adjusting the primary air flow”.

Burner	Rated heat Capacity (kW)	Natural gas - G20 20 mbar	
		Nozzle diameter 1/100 mm	Reduced heat capacity (W)
Auxiliary	1.05	73	400
Semi rapid	1.7	92	450
Rapid	3.0	123	1050
Ultra Rapid	4.2	150	1400

5.4 Adjusting the primary air flow

Refers to the gap “X” in mm.

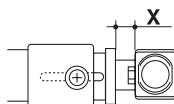

BURNER	G20 20 mbar	G30/G31 30/37 mbar
Auxiliary	0.5	3
Semi rapid	0.5	2
Rapid	2	3
Ultra Rapid	4	10

To identify the burners on your hob, refer to the drawings in point “5.8 Hob burner layout”.



Instructions for the Installer

5.5 Reassembling the hob skin

Reverse the procedure described in point "5.1 Removing the hob skin".
Fit the pan stands as described in point "7.1 Fitting the Pan Stands".

5.6 Adjusting the minimum for natural gas

Reassemble the components on the burner and fit the knobs onto the tap rods.

Light the burner and turn it to the minimum setting. Remove the knob again and adjust the regulator screw inside or beside the tap rod (depending on the model) until an even minimum flame is obtained. Put the knob back in place and check the stability of the burner flame (the flame must not go out when the knob is turned quickly from the maximum to the minimum setting).

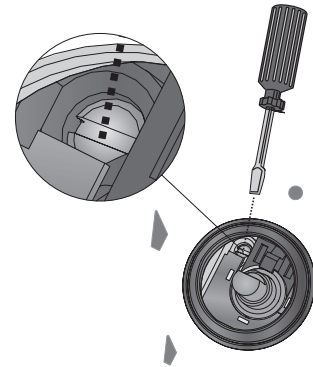

5.7 Adjusting the minimum for bottled gas

To adjust the minimum level when using bottled gas, the adjuster screw inside or beside the tap rod must be turned fully clockwise (depending on the models). The diameters of the bypasses for each individual burner are stated in point "5.2 Adjusting for bottled gas".



After adjusting for use of a gas other than the gas used for testing the appliance, replace the label on the casing with the label for the new gas. The label is supplied in the bag with the LPG nozzles (G30 - G31).

5.8 Hob burner layout

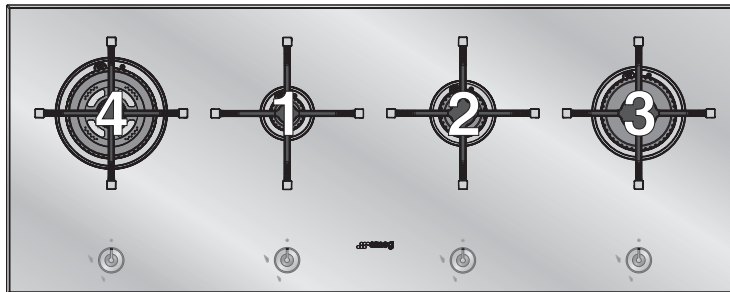

Burner type

- 1 Auxiliary
- 2 Semi rapid
- 3 Rapid
- 4 Ultra rapid

5.9 Greasing the gas taps

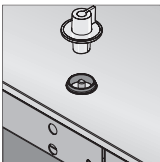

Over time, the gas taps may become stiff or jam. Clean their insides and change their lubricating grease. **This operation must be carried out by a skilled technician.**



6. Description of controls

6.1 The front panel

All the hob's control and monitoring devices are placed together on the front panel.



CONTROL AREA



4 Burner Hob

KNOB OPERATING MODE

To light the flame, press the knob and at the same time turn it anti-clockwise to the minimum flame symbol .

To adjust the flame, turn the knob to the zone between the maximum  and the minimum  settings.

To turn off the burner, turn the knob back to the O position.

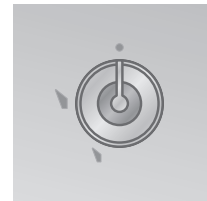

KNOB – BURNER COMBINATIONS

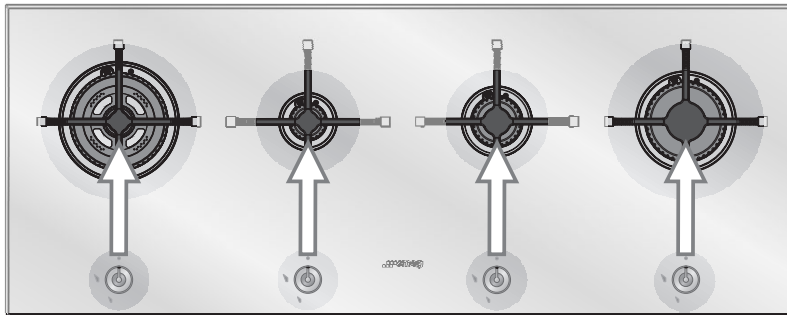



Instructions for the User

7. Using the hob



Check that the burners, flame diffuser rings and pan stands are fitted correctly.

The projections **A** on the flame diffuser rings must be fitted into the recesses **B** in the burner. The holes **C** in the burner must mate with the ignition plugs and thermocouples **D** on the hob.

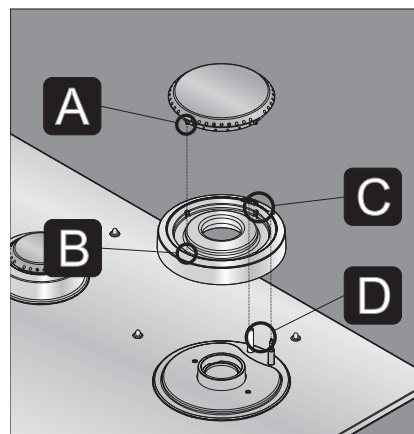

7.1 Fitting the Pan Stands

The pan stands are supplied dismantled from the hob. To place each pan stand on its burner correctly, follow the instructions provided below:

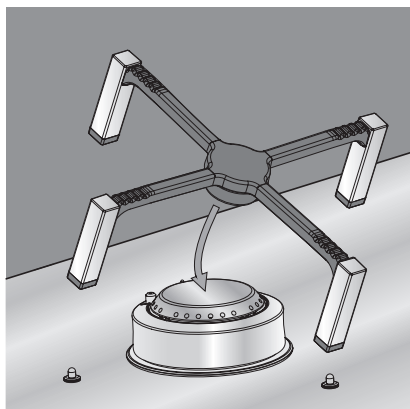

Each pan stand must be positioned on the corresponding burner in order to guarantee proper operation.

Be very careful to match the different central diameters of the pan stands to the flame-spreader crowns.

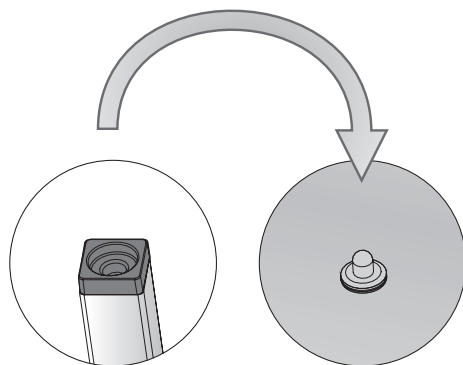

At the ends of the legs of the pan stands there are silicone gaiters with a hole that must be centred onto the matching fixing pins on the hob.

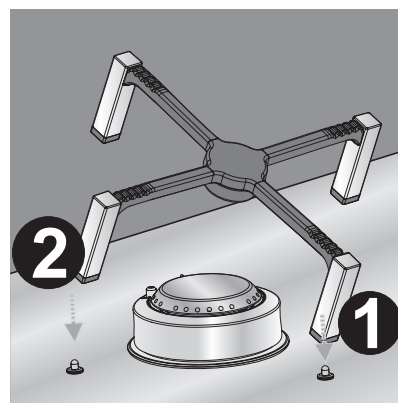

To position the pan stand, you first need to centre the fixing pins (1) and (2) and then lower it until it is resting on the hob. When properly positioned, the legs of the pan stands must not hang above the hob but should rest on top of it.

Instructions for the User



GB-IE



Make sure that the pan stands are simply fitted over their burners, and are not left in a raised or tilted position; if this occurs, repeat the fitting procedure.

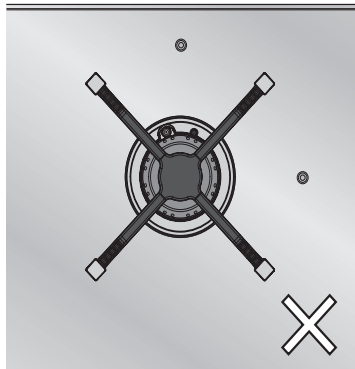

WRONG

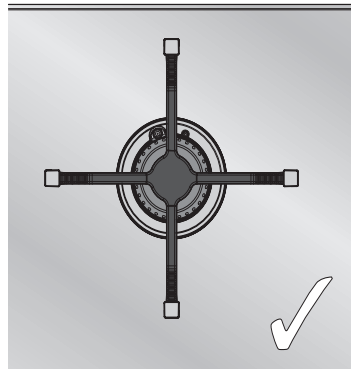

RIGHT

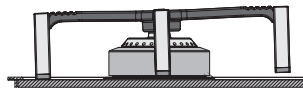

WRONG

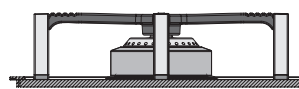

RIGHT

After performing the operations described above (for each pan stand), the hob will be as shown below, with the feet of the pan stands forming a pattern of horizontal and vertical lines.

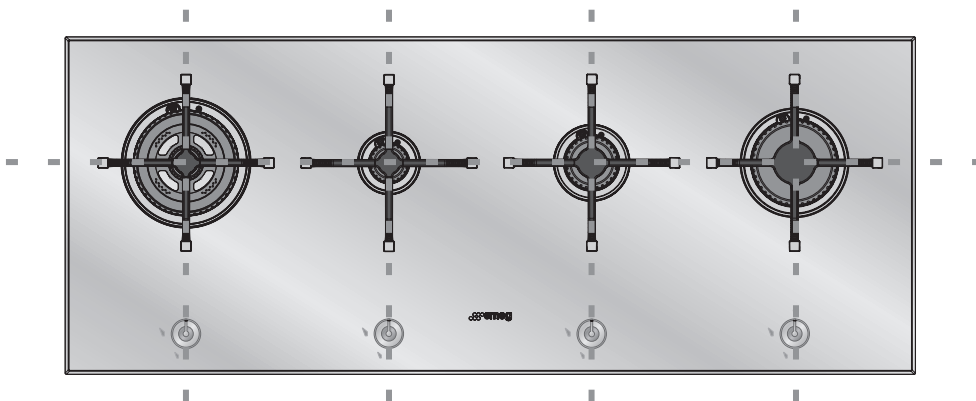

If a pan wobbles noticeably, check that the pan stands have not been fitted incorrectly.



Instructions for the User

7.2 Lighting burners with safety device



The burner it controls is shown next to each knob (the example here shows the front left-hand burner).

The appliance is equipped with electronic ignition. Simply press the knob and turn it anti-clockwise to the minimum flame symbol , until the burner lights. Keep the knob pressed down for about 2 seconds to keep the flame alight and prime the safety device. The burner may go out when the knob is released. In this case, repeat the operation, keeping the knob pressed down for longer.



When the burner has lit, its control knob will light up to confirm that it is in operation. The knob will go out a few seconds after it is turned to the O position, or if the burner goes out accidentally. The knob light comes on and goes out gradually.



If the burners should go out accidentally the safety device will be tripped about 20 seconds later, cutting off the gas supply even if the gas tap is open.

7.3 Practical hints for using the burners

For better burner efficiency and to minimise gas consumption, use flat, even -bottomed pans with lids of suitable size for the burner (see point "7.4 Pan diameters").

When cooking, to prevent burns or damage to the hob all pans or griddle plates must be placed inside the perimeter of the hob and must be at least **5-7 cm** from the knobs.





7.4 Pan diameters

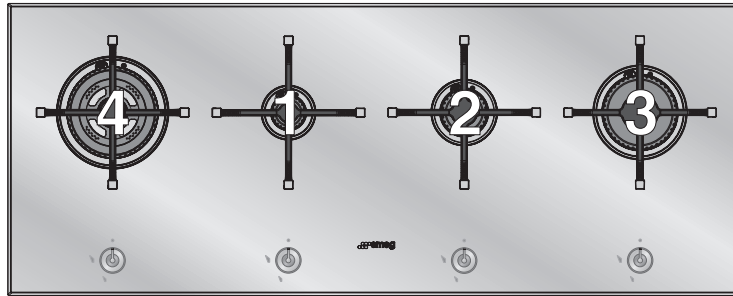
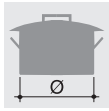

BURNERS	min. and max. Ø (in cm)
1 Auxiliary	7-18
2 Semi rapid	10-24
3 Rapid	18-24
4 Ultra rapid	20-26



Instructions for the User

8. Cleaning and maintenance



Before carrying out any operations, disconnect the appliance from the electricity supply.



Never use a jet of steam for cleaning the appliance.

8.1 Cleaning the hob



To keep the hob in good condition, it must be cleaned regularly, after each use, first allowing it to cool.

8.1.1 Routine daily glass hob cleaning

When cleaning and caring for glass surfaces always use **only** specific products which do not contain abrasives or chlorine-based acids.

Instructions for use: pour the product onto a damp cloth and wipe over the surface, then rinse thoroughly and dry with a soft cloth or chamois leather.

8.1.2 Food stains or spills

Never use metal scouring pads or sharp scrapers which will damage the surface.

Use ordinary non-abrasive products for glass, with the aid of non-scratching sponges and wooden or plastic utensils if necessary.

Rinse thoroughly and dry with a soft cloth or chamois leather.



8.2 Cleaning the components



Never clean the knobs with aggressive products containing alcohol or steel or glass cleaners, since they might cause permanent damage.



The components described below must never be washed in a dishwasher.

8.2.1 The knobs

The knobs must be cleaned with a soft cloth dipped in warm water and dried thoroughly. They can easily be lifted off.

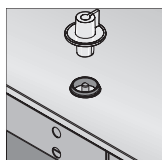

8.2.2 The pan stands

Remove the pan stands and wash them in warm water with a non-abrasive detergent, taking care to remove all deposits. Replace them on the hob following the instructions provided in point "7.1 Fitting the Pan Stands".



8.2.3 The flame diffuser rings

The burner caps and flame diffuser rings can be removed for easier cleaning; wash them in hot water and non-abrasive detergent, taking care to remove all deposits, and wait for them to **dry completely**.

The burner pins **A** must be fitted into the recesses **B** in the flame diffuser ring. The holes **C** in the flame diffuser ring must mate with the ignition plugs and thermocouples **D** on the hob.

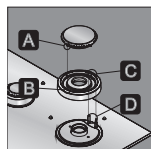

8.2.4 The plugs and thermocouples

For best performance, the ignition plugs and thermocouples must always be kept thoroughly clean. Check them frequently and if necessary clean them with a wet cloth. Remove any dry residues with a wooden toothpick or a needle.

